

Implementation of EM 385-1-1, 2014

Professional Development Seminar

March 2015

U.S. Army Corps of Engineers
HQ Safety & Occupational Health

EM 385-1-1
30 November 2014

SAFETY AND HEALTH
REQUIREMENTS MANUAL



US Army Corps of Engineers
BUILDING STRONG

BUILDING STRONG...SAFELY!

AGENDA

- EM 385-1-1, 2014 background and facts
- Review of significant changes to EM, by section with implementing guidance
- Q&As [how they will be handled]
- Closing Comments



Implementation

By definition ... Implementation is the process of putting a decision or plan into effect; execution.

This presentation looks at each Section of the manual and provides guidance with respects to the execution of these NEW changes



Details

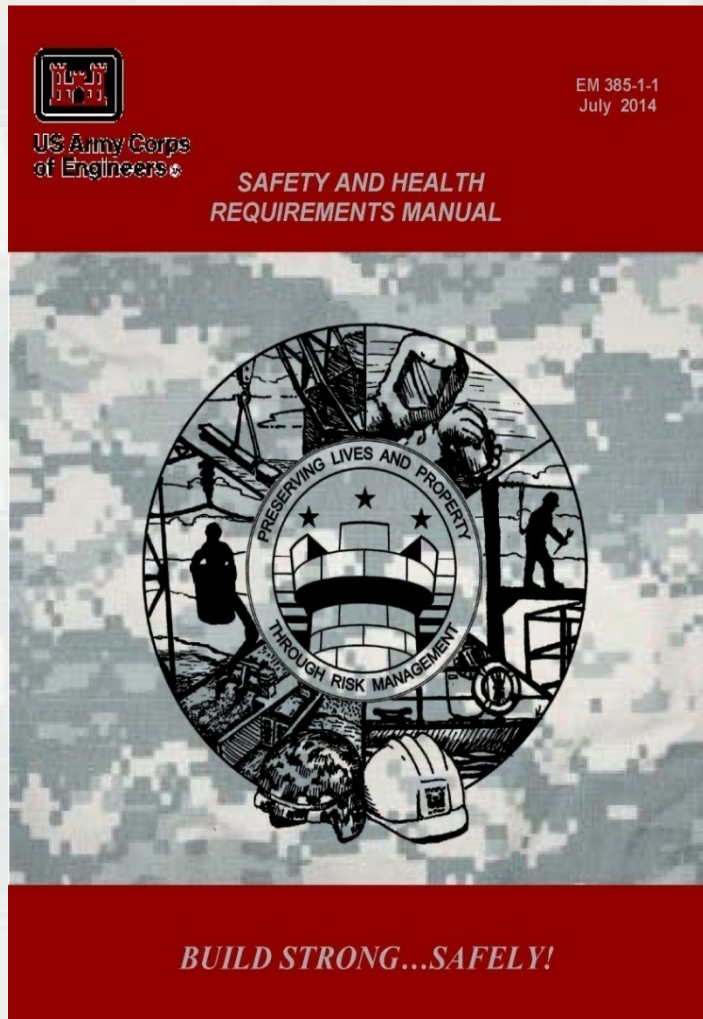

- 8 ½” x 11” format, 3-hole punched to fit standard binder
- Approx. 950 pages (vs. 1,100)
- Over 750 comments submitted
- Focus on collaboration with industry, government, public



Details

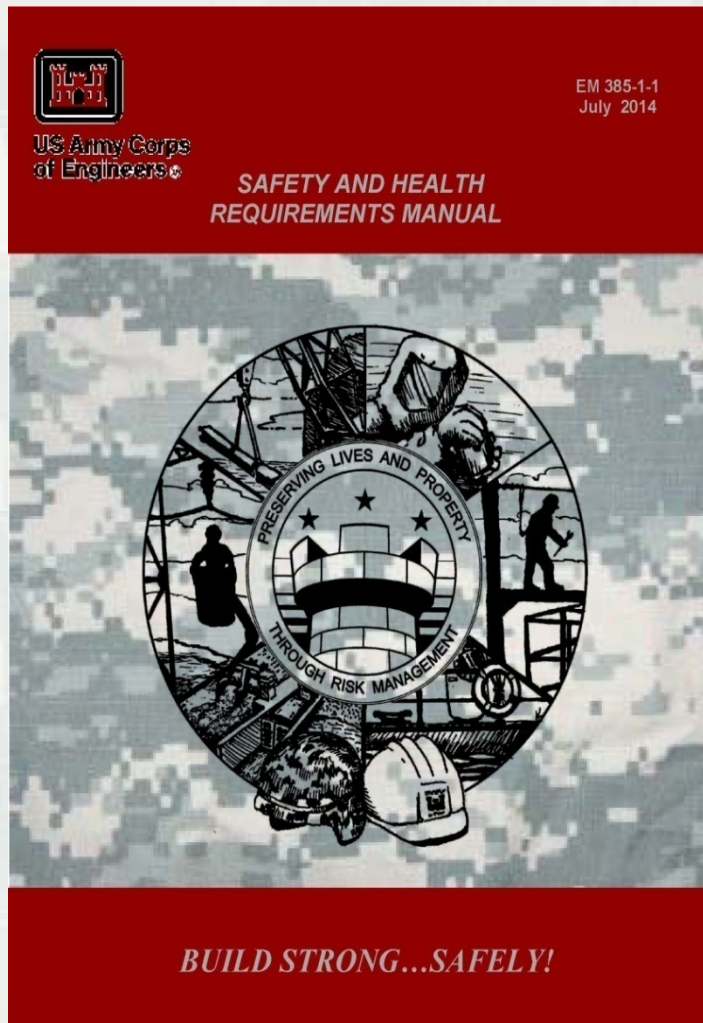

- Still 34 sections
- Appendices stacked consecutively – A thru G and Q=definitions
- Appendices H-R blank
- Cover Letter in front basically the same but important – READ !



There's an APP for this !



Section 1 – Program Management

01.A.02 Employer is responsible for maintaining a SOH Program...

Note 1: Supplementation of this manual is not authorized except as published by the SOH Office, HQUSACE.

Note 2: Local USACE Commands may develop Standard Operating Procedures (SOPs) to implement the provisions contained within this manual, but may not implement new requirements (e.g., more stringent, differing in intent, etc.), without the specific approval of HQUSACE-SO.

Rationale: Nationalized Consistency.





Section 1.A.12 – Accident Prevention Plans

01.A.12 Accident Prevention Plans (APP) for Contract Work.

a.(1) The Contractor shall identify each major phase of work that will be performed on this contract. Within each major phase, all activities, tasks or Definable Features of Work (DFOWs) shall be identified **and will require an AHA**. > See Section 01.A.14.

Rationale: AHA's will NOT be turned in with the APP. This has become a paperwork exercise that defeats the true intent/value of the AHA process.





Section 1.A.14 – Contractor RM Process/AHAs

01.A.14 Contractor Risk Management Process (AHAs) – identifies what a RM Process is and says the AHA is what the USACE assessment tool is.

Added note saying contractors and others may use Job Safety Analyses (JSAs), Job Hazard Analyses (JHAs), or similar RM assessment tools and that these are considered equivalent to, and acceptable substitutes for, the USACE's AHA provided the data collected is the same as that required by the AHA.

Rationale: Contractors may use JSA's but other RM assessment tools are acceptable if info is equivalent.



Section 1.A.14 – Contractor RM Process/AHAs

01.A.14 Contractor Risk Management Process (AHAs)

- b. Before beginning each work activity, task or (DFOW), the Contractor performing that work activity shall prepare the initial AHA. A Risk Assessment Code (RAC) is assigned to each step, to the risk that remains after controls have been applied (residual risk).

Rationale: AHAs shall be prepared by the persons with the knowledge of that activity (not necessarily the GC). AHAs are submitted just prior to that work being performed instead of when APP is submitted.



Section 1.A.14 – Contractor RM Process/AHAs

01.A.14 Contractor Risk Management Process (AHAs)

- d. AHA's are intended to be developed and used by the field crews/workers performing the work, with the assistance of others (SSHO, QC, Superintendent, etc) as needed. The initial, accepted AHA shall be provided to and used by the field crews/workers that are performing that activity. AHAs are to be considered living documents and are intended to be created in the field and updated by the workers as needed.

Rationale: Same as previous slide. AHAs shall be prepared by the persons with the knowledge of that activity. Those performing the work shall know of, and shall follow that AHA. SOPs for updating are in this section as well.



Section 1.A.17 – Contractor SSHO

01.A.17 Contractor Site Safety and Health Officer (SSHO).

Experience: **5 yrs** of continuous construction or industrial SO experience in supervising/managing safety programs or processes or conducting hazard analyses and developing controls, or 4 yrs if SSHO has a Third-Party, Nationally Accredited (ANSI or NCCA) SOH-related certification (defined in App Q)

Maintain competency - **8 hrs** of documented formal, on-line, or self-study safety and health related coursework every year.



Section 1.A.17 – Contractor SSHO

01.A.17 Contractor Site Safety and Health Officer (SSHO).

Projects with multiple shifts: Alternate SSHO allowed. Alternate is equivalent to SSHO.

If SSHO is off-site for >24 hours: Alternate SSHO provided.

If SSHO is off-site for \leq 24 hours: Designated Representative (DR) can be used. DR=collateral duty person.

If Definable Feature of Work/activity has multiple sites AND RAC is low or medium, DR is appointed at each site if >45 minutes travel to SSHO



Section 1.A.17 – Contractor SSHO

01.A.17 Contractor Site Safety and Health Officer (SSHO).

EXCEPTIONS:

Dredging contracts: SSHO requirements established in standardized contract clause for dredging project site safety personnel shall be used as it is included in the current UFGS

Limited service contracts – e.g., mowing only, park attendants, rest room cleaning), the KO & SOHO may modify SSHO requirements and waive more stringent elements

Field walk-over, surface soil sampling, or long term water sampling (no exposure to mechanical/explosive hazards), the SSHO may be collateral duty; shall have a min. 8 hrs of training/year and specific knowledge of the potential hazards of the tasks being completed.



01.A.20 Fatigue Management Plan (FMP)

A FMP shall be completed as part of the APP/Project SOH plan whenever work hours:

- Exceed 10-hrs/day for more than 4 consecutive days;
- Exceed 50-hours in a 7-day work week;
- Exceed 12-hrs/day for more than 3 consecutive days, or
- Exceed 58-hrs/week for sedentary (includes office) work.

Also – added reference to “rest” and what it means per App Q

Rationale: USACE has had mishaps where direct cause is related to fatigue. FMP is a chance to allow long or demanding work hours when needed but insures that fatigue is considered as a risk factor.



01.A.20 Fatigue Management Plan

b. The FMP shall address the following conditions for operator work hour limitations:

Equipment Operators – same as before, not permitted to exceed 12-hours of duty time in any 24-hour period, without a minimum of 8 consecutive hours of rest between shifts in a 24-hour period.

Motor Vehicle Operators – same as before - while on duty, shall not operate vehicles for a continuous period of more than ten 10-hours in any 24-hour period;

Rationale: realizes that long hours are sometimes needed but insures fatigue as a risk factor is considered.



01.A.20 Fatigue Management Plan

b. The FMP shall address the following conditions for operator work hour limitations:

Floating Plant – (moved from Section 19). All floating plant personnel shall be scheduled to receive a minimum of 8-hours rest in any 24-hour period, except:

When quarters are provided immediately adjacent to, or aboard the work site, these hours of rest may be divided into no more than 2 periods, one of which must be at least 6 continuous hours in length.

Rest periods may be interrupted in case of emergency, drill, or other overriding operational necessity.



01.A.20 Fatigue Management Plan

c. FMP shall identify affected workers, management responsibility, training, and the controls established at the worksite.

(1) Training shall include symptoms of fatigue, worker habits, controls to prevent, ect..

(2) Controls for fatigue may include work scheduling (limit number of consecutive night shifts), rotating jobs to prevent repetitive work, breaks at critical times in the work cycle, control of environmental factors (heat, cold, use of personal protective equipment), buddy check-in for individuals working alone, and alternate transportation for long commutes.

Rationale: Fatigue factors and controls must be evaluated and planned.



01.D Mishap Reporting and Investigation

01.D.01 A mishap is any unplanned, undesired event that occurs during the course of work being performed. The term “mishap” includes accidents, incidents and near misses. > See Appendix Q and reporting thresholds and criteria in Section 01.D.03.

Recordable property damage threshold increased from \$2K to \$5K – per Dept. of Army

Days Away Injuries/Illnesses

Restricted/Transfer Injuries

Rationale: New reporting threshold & terminology.



01.D Mishap Reporting and Investigation

01.D.05 ANY mishap in one of 4 High Hazard areas shall be reported immediately to GDA/CESO

- Electrical – including Arc Flash and Uncontrolled release of Hazardous Energy
- LHE/Rigging
- Fall-from-Height
- Underwater Diving

Note: The reporting and associated investigation of these mishaps is considered a leading indicator. As such, this information is to be used for data collection, data trending and correction of hazards or program deficiencies before they result in an accident. To encourage reporting of these mishaps, this data is NOT to be used for any other purpose.



Section 3 - Medical and First Aid Requirements

In 03.A.02 and in 03.B.04, required all First Aid, CPR, and AED training contain hands-on component and NOT be allowed to be taken completely on-line. Also required retraining a minimum of every two years.

Required all AEDs in a location be the same manufacturer and model and clearly defined maintenance program for AEDs.



Section 4 - Temporary Facilities

Para. 04.A.05: After subject line of “Temporary Work Camps (Floating Plant Excluded)” added “The design and construction of work/labor camps shall be IAW 29 CFR 1910.142.”

Refers to Code of Federal Regulation governing Temporary Labor Camps.

Para. 04.A.07 (new): Added new subject, “Temporary Explosives Storage Areas. Temporary Explosive Storage Areas shall be IAW the EM 385-1-97 (Explosives Safety and Health Requirements) Chapter 1, Section 2, Subpart 1.2.N”.

Clarifications/highlight these storage areas and reference to follow.



Section 4 - Temporary Facilities

Para. 04. B.10.b: Currently reads “Truck haul roads should be kept to less...” changed to “Access/Haul roads should be kept to less than a 10% grade. There should be no more than 400 ft (121.9 m) of grade exceeding 10%.”

Need to address that haul roads are not exclusive to trucks.



Section 5 - Personal Protective and Safety Equipment

05.C Hearing Protection and Noise Control requires contractors to comply with ACGIH, have a written program, training, and pre and post work hearing tests.



Section 5 - Personal Protective and Safety Equipment

05.D.02 Allows for stickers on hard hats provided they do not interfere with the ability to properly inspect it.

05.D.02 All protective headgear shall meet the requirements of ANSI Z89.1.

a. No modification (i.e. paint) to the shell or suspension is allowed except when such changes are applied or approved by the manufacturer. Stickers are allowed on the hard hat provided they do not interfere with the ability to properly inspect it. > See 05.D.03.



Section 5 - Personal Protective and Safety Equipment

05.F requires reflective vests if exposed to vehicular traffic > 35 mph; night work requirements; and allows for deviation based on heat or if greater hazard is created

Para. 5.F.02: b. Workers are exposed to vehicular or equipment traffic in excess of 35 mph (56.3 kph)



Section 5 - Personal Protective and Safety Equipment

Para. 05.F.03 When working at night, on or near sites where vehicle traffic is present, workers (such as, but not limited to, signal persons, spotters, survey crews and inspectors) shall wear, at a minimum a **Class 3 high-visibility** safety coverall/jumpsuit or a **Class 3 high-visibility safety jacket** and **Class E high-visibility pants, or bib**



Section 5 - Personal Protective and Safety Equipment

05.F.04 If the use of High Visibility apparel proves to create a greater hazard due to moving machinery, pinch points, heat stress or other reasons, an AHA detailing rationale for infeasibility of use and alternate safety measures to be used to ensure same level of worker safety, shall be developed, signed and submitted by the responsible person and accepted by the GDA, supervisor or the command's local Safety and Occupational Health Office (SOHO). Work shall not commence until such acceptance has been obtained.



Section 5 - Personal Protective and Safety Equipment

Para. 05.H Moved FP harness standards to Section 21.

Added a new paragraph on Hand Protection. The paragraph requires proper selection, training, and inspection of hand protection and provides a table on the suggested types of hand protection.

Para. 05.H.01 Employers shall select and require employees to use appropriate hand protection when employees' hands are exposed to hazards such as skin absorption of harmful substances, severe cuts or lacerations, severe abrasions, punctures, chemical burns, thermal burns, harmful temperature extremes, high hand vibration and sharp objects.



Section 6 - Hazardous or Toxic Environments

06.A.03 Added: “Regular housecleaning (work and break area surface cleaning) and personnel decontamination procedures shall be instituted in areas where the operations generate toxic dust and fume hazards. The frequency of surface cleaning and of decontamination procedures is dependent on the nature of the hazards and frequency and risk from the exposure and shall be documented in the project safety plan or accident prevention plan.”

Reason: OSHA regulations for lead, chromium, and cadmium.



BUILDING STRONG®

Section 6 - Hazardous or Toxic Environments

HCS Pictograms and Hazards

<p>Health Hazard</p>  <ul style="list-style-type: none"> • Carcinogen • Mutagenicity • Reproductive Toxicity • Respiratory Sensitizer • Target Organ Toxicity • Aspiration Toxicity 	<p>Flame</p>  <ul style="list-style-type: none"> • Flammables • Pyrophorics • Self-Heating • Emits Flammable Gas • Self-Reactives • Organic Peroxides 	<p>Exclamation Mark</p>  <ul style="list-style-type: none"> • Irritant (skin and eye) • Skin Sensitizer • Acute Toxicity (harmful) • Narcotic Effects • Respiratory Tract Irritant • Hazardous to Ozone Layer (Non Mandatory)
<p>Gas Cylinder</p>  <ul style="list-style-type: none"> • Gases under Pressure 	<p>Corrosion</p>  <ul style="list-style-type: none"> • Skin Corrosion/ burns • Eye Damage • Corrosive to Metals 	<p>Exploding Bomb</p>  <ul style="list-style-type: none"> • Explosives • Self-Reactives • Organic Peroxides
<p>Flame over Circle</p>  <ul style="list-style-type: none"> • Oxidizers 	<p>Environment (Non Mandatory)</p>  <ul style="list-style-type: none"> • Aquatic Toxicity 	<p>Skull and Crossbones</p>  <ul style="list-style-type: none"> • Acute Toxicity (fatal or toxic)

6.B.01 Added changes to be compliant with the Globally Harmonized System Changes to the Hazard Communication Standard



Section 6 - Hazardous or Toxic Environments

06.D Moved discussion of melting pots to Section 09.

Added: “06.D.01 c. Location where hot substances are heated shall be located away from any ventilation intake air vents. If hot substances are being applied to a roof, the ventilation intake air vents shall be temporarily relocated so as to prevent the uptake of the fumes into the building or the work shall be completed at a time when the building is not occupied.”



Section 6 - Hazardous or Toxic Environments

06.J. Heat/Cold Stress Management was rewritten. Below are the major changes are:

- Move the Inclement Weather to Section One
- Removed the ACGIH tables
- Monitoring WBGT or table of approximate WBGT
- Cold Stress set criteria for including cold in APP: low temperatures and wind chills, bare hand work, refrigerated room work

Rationale: Response to several heat related injuries.



Section 6 - Hazardous or Toxic Environments

Added to 06.H.01 – Allowed recirculation of filtered air with provisions:

- a. Air sampling shows it is safe.
- b. Not generating chromium or beryllium
- c. Sampling includes carbon monoxide, ozone, and carbon dioxide
- d. Air not re-circulated into a confined space
- e. Filter is on a regular maintenance schedule

Rationale: In response to a request for clarification



Section 7 - Illumination

Section 7.A : Added Section summary statement – not in previous editions.

Equipment Requirement added

07.A.02 While work is in progress, offices, facilities, access ways, working areas, construction roads, etc., shall be lighted by at least the minimum light intensities specified in Table 7-1. Illumination readings shall be taken and recorded whenever proper lighting of an area is in question. A calibrated light meter shall be provided, maintained and used as necessary to provide illumination readings.



Section 7 - Illumination

Added requirement for portable light carts.

07.A.10 Generator-powered portable lighting units shall be grounded in accordance with manufacturer's instructions. In addition, a survey of the area to be lighted will be conducted and documented to ensure overhead power lines do not pose a hazard.





Section 8 - Accident Prevention Signs, Tags, Labels, Signals, Piping System Identification & Traffic Control

Section 8.A: Updated references & provided additional OSHA, ANSI, ASME references

Para. 08.A.06: Updated Warning Sign background to Orange

Para. 08.B.04, 11, 12: All address backing up, signal person use and back-up alarms. Bold paragraph and added note to emphasize and reference as a result of a USACE vehicle related fatality:

“Note: This applies to operations covered in Section 18.”



Section 9 - Fire Protection and Prevention

09.A.04 Hot Work Permits.

Defined when should be required:

The GDA shall survey all activities and determine which require a hot work permit. All hot work and hot work permits shall conform to local policy, when present.

a. Hot work permits shall be required when performing activities which generate or have the potential to generate, heat, sparks, or open flames, such as abrasive blasting, burning, brazing, cutting, grinding, powder-actuated tools, hot riveting, soldering, thawing activities, welding, or any similar operation capable of initiating fires or explosions.



Section 10 - Welding and Cutting

Defined a safe distance for workers adjacent to arc welding and clarified requirements for welding curtains.

10.A.04 Arc welding and cutting operations shall be shielded by noncombustible or flameproof screens that will protect employees and other persons working within 35 ft (12.18 m) from the direct rays of the arc, sparks, molten metal, spatter, and chipped slag.

a. Welding curtains shall be suitable for the welding process and amperage.

b. Welding curtains shall provide a high degree of safety against ultraviolet radiation and blue light.



Section 10 - Welding and Cutting

Defined a safe distance for workers adjacent to arc welding and clarified requirements for welding curtains.

10.A.04 Arc welding and cutting operations shall be shielded by noncombustible or flameproof screens that will protect employees and other persons working within 35 ft (12.18 m) from the direct rays of the arc, sparks, molten metal, spatter, and chipped slag.

c. Welding curtains shall be fade resistant and flame retardant.

d. The use of blue tinted welding curtains is prohibited if observers are in the work area as they provide very little blue light protection.



Section 10 - Welding and Cutting

Para. 10.D.03 Added a requirement for 60-minute fire watch. Added as a recommended action after a fire mishap.

10.D.03.c. When welding or cutting must be done in a location where combustible or flammable materials are located, inspection and authorization by the GDA shall be required before such operations are begun. During welding or cutting, a fire watch shall stand with a fire extinguisher equipment readily available and be trained in its use and in sounding an alarm in the event of a fire. A fire watch shall be maintained for at least **one hour** after completion of the welding or cutting operation to extinguish possible smoldering fires.



Section 10 - Welding and Cutting

Added new 10.H to address requirements for Plasma Cutting – method used but not previously addressed

10.H Plasma Cutting.

10.H.01 Plasma arc cutting equipment shall be installed, maintained, and operated in accordance with the NEC and manufacturer's instructions.

10.H.02 All cables and torch leads shall be inspected before each use. Any damaged cables and torch leads shall be replaced before use.

10.H.03 All consumables (nozzles, electrodes, etc.) shall be verified for proper installation before each use.

10.H.04 All torches used in plasma cutting shall contain a trigger safety device to prevent accidental contact.

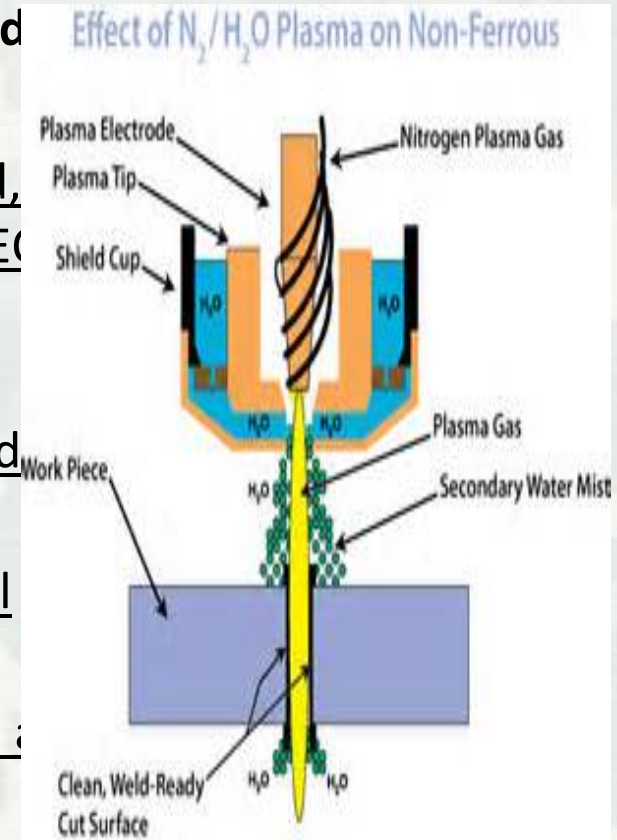

Section 10 - Welding and Cutting

Added new 10.I to address requirements for Thermite Welding - method used but not previously addressed.

10.I Thermite Welding

Thermite is a pyrotechnic composition or metal powder fuel and metal oxide. When ignited by heat, thermite undergoes an exothermic oxidation-reduction reaction. Most varieties are not explosive but can create brief bursts of high temperature in a small area.



Section 11 - Electrical

ADDED 11.A.01.e: Emergency Procedures and training. Employees exposed to shock hazard and those employees responsible for taking action in case of emergency shall be trained in methods of release of victims from contact with exposed energized electrical conductors or circuit parts. Employees shall be regularly instructed in methods of first aid and emergency procedures, such as approved methods of resuscitation, if their duties warrant such training.



Section 11 - Electrical

Training of employees in approved methods of resuscitation, including cardiopulmonary resuscitation and automatic external defibrillator (AED) use, shall be certified by the employer annually.
> See Section 03.A and OSHA 29 CFR 1910.151 and NFPA 70E 110.2(c).

Rationale: Insure workers are prepared for an electrical mishap.



Section 11 - Electrical

ADDED Arc Flash-specific wording:

11.A.08: Suitable barriers or other means shall be provided to designate arc flash boundaries that ensure workspace for exposed energized electrical equipment cannot be used as a passageway.

Rationale: Provide more AF-related details to requirements due to number of AF-related mishaps incurred.



Section 11 - Electrical

ADDED Arc Flash-specific wording:

11.B.08 Arc flash labeling must be placed on energized equipment. Labels are required to warn of potential electrical arc flash hazards and appropriate PPE. Labels, at minimum, shall include:

- a. Limits of approach; b. Nominal system voltage; c. Hazard/Risk category (required PPE); d. Incident energy at working distance.

Rationale: Provide more AF-related details to requirements due to number of AF-related mishaps incurred.



Section 11 - Electrical

11.B.09: All personnel entering the identified arc flash protection boundary must be QPs and properly trained in NFPA 70E requirements and procedures. Training must be administered by an electrically qualified source and documented.

Provides for required level of skill/training as required inside AF boundary.



Section 11 - Electrical

11.C.01.f: Access and working space shall be provided and maintained around all electrical equipment to permit ready and safe operation and maintenance in accordance with NFPA 70 equipment space requirements. Where clearance is not feasible (i.e., floating plants, vessels), procedures shall be in place to insure sufficient clearance for fully opening the door and/or servicing the electrical enclosure shall be maintained.

Space requirements must be met. If not feasible due to configuration of workspace, equivalent level of safety must be provided via procedures in place.



Section 11 - Electrical

Added wording:

11.D.05 Ground-Fault Circuit-Interrupter (GFCI) Protection For Personnel. All receptacle outlets (125-volt, 15-, 20-, 30- amperage and greater) that provide temporary electrical power during construction, remodeling, maintenance, repair, or demolition shall have ground-fault circuit-interrupter (GFCI) protection for personnel. > See NEC, Article 590.6 and 29 CFR 1926.404(b); See also paragraph 11.D.05.g below.

Clarifies that ALL outlets providing temporary power shall be protected. Referenced paragraph g points to AEGCP and Appendix E for higher voltage or troublesome/sensitive equipment that nuisance trips the GFI.



Section 11.E.04 – Wet Locations

11.E.04 Wet Locations. An Activity hazard Analysis (AHA) shall be developed by the work crew for these activities.

a. Electric pumps may be used to support periodic maintenance and/or construction activities only when the pump is designed by the manufacturer to operate in wet locations.

(1) The pump shall be installed and tested by a QP and operated by personnel trained to the appropriate level.

(2) When personnel are, or could be, present in the water during pump operation, the pump shall be equipped with a Ground Fault Circuit Interrupter (GFCI), except as noted in (3) below.



Section 11.E.04 – Wet Locations

Note: If pump manufacturer does not allow personnel in the area when pumps are used in water, an appropriate Control of Hazardous Energy Program, to include lockout/tagout, must be in place. > See Section 12.

(3) Where conditions of maintenance and supervision ensure that only qualified personnel are involved, an Assured Equipment Grounding Conductor Program (AEGCP, see Appendix E) shall be permitted for those receptacle outlets used to supply equipment that is not compatible with GFCI protection or that would create a greater hazard if power was interrupted. > See section 11.D.05.g, NEC, Article 590.6 and 29 CFR 1926.404(b).



Section 12 – Control of Hazardous Energy

Section 12.A

Deleted current Para. 12.A.01 and changed to “When working on or near any system that produces, uses, or stores hazardous energy, a hazardous energy control program (HECP) is required see 12.B. Hazardous energy is any energy, including but not limited to mechanical (e.g., power transmission apparatus, counterbalances, springs, pressure, gravity), pneumatic, hydraulic, electrical, chemical, nuclear, and thermal (e.g., high or low temperature) energies, that could cause injury to employees.”

Rationale: Workers have not considered sources of energy besides electrical. They are frequently overlooked/not addressed in AHAs, LOTO procedures, etc. This clarifies they are important too.



Section 12 – Control of Hazardous Energy

Note added after Section 12 .A.01.a: When a site is controlled by a contractor and USACE employees are affected by contractor managed HECP (e.g., QA's on construction sites, etc.), they shall comply with the contractor's HECP.

Note was added to clarify that when this occurs, everyone knows which regulation that they are to follow.

New Para. 12.A.01.b(1) replaces the current 12.A.01 which addresses that the contractor is required to follow 1910.147, ANSI Z244.1, and ANSI A10.44.



Section 12 – Control of Hazardous Energy

Current Para. 12.A.12 is now section **12.B. Hazardous Energy Control Program (HECP)**. 12.B. 01 now reads “The HECP shall clearly and specifically outline the scope, purpose, authorization, roles, and responsibilities, rules, and techniques to be used for the control of hazardous energy, including, but not limited to the following.”

12.A.12.b.(4) is now 12.B.02.d ; has removed “tagout devices” – intent is to ensure that tags are no longer a substitute for locks which is addressed in 12.E locks and tags.



Section 13 – Hand and Power Tools

- 13.D.01 Safety clips or retainers shall be installed and maintained on pneumatic impact (percussion) tools to prevent attachments from being accidentally expelled.
- a. All hoses exceeding ½-in (1.3cm) inside diameter shall have a safety device at the source of supply or branch line to reduce pressure in case of hose failure.
 - b. Compressed air pressure and volume shall be regulated according to manufacturer's rating for the tool.



Section 13.E – Explosive-Actuated Tools

Added new:

13.E.10 If the powder-actuated tool misfires, the employee shall wait at least 30 seconds, then try firing again. If the tool will not fire after a second attempt, the employee shall wait at least another 30 seconds before removing the faulty cartridge. The faulty cartridge shall be placed in water until disposal. Disposal shall follow manufacturer's instructions.

Rationale: to reduce misfire mishaps.



Section 14, Material Handling, Storage, and Disposal

14.C.02 Materials that could become damaged or affected by exposure to the elements shall be adequately covered or stored indoors.

14.C.03 Materials shall not be stored in areas that would interfere with other normal operations.

14.C.04 Materials shall not be stored directly under power lines.

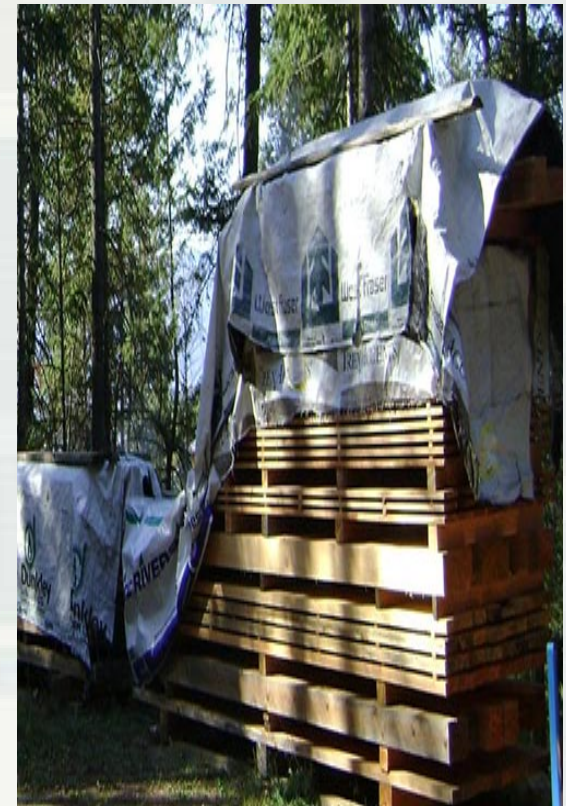

Section 14, Material Handling, Storage, and Disposal

14.C.05 Material storage shall be in compliance with manufacturer's recommendations.

14.C.09 Material shall not be stored on scaffolds, work platforms, or runways in excess of the standards in Section 22.

New wording is specific and based on near misses and actual incidents that have occurred.



Section 15.A General

15.A.05 Custom fabricated grabs, hooks, clamps, or other lifting accessories (e.g., equalizing beams, lifting or spreader beams, etc.) for such units as modular panels, prefabricated structures, and similar materials shall be designed by an Registered Professional Engineer (RPE), marked to indicate the WLL and shall be proof-tested before initial use, to 125% of their WLL.



15.B - Personnel Qualifications

15.B.01 - Any worker engaged in the duties and the performance of rigging shall be a Qualified Rigger (QR). Employers must determine and designate in writing the QRs and the specific rigging tasks for which they are qualified and provide to the GDA for acceptance.

Note: The term “rigger” or “Qualified Rigger (QR)” in this manual refers to the function performed, and in no way relates to the worker’s job classification or position.



15.B – Personnel Qualifications

a. Each QR may have different credentials or experience. A QR is a person that:

- (1) Has extensive knowledge, training and experience sufficient to calculate loads, load weights, safe capacities and apply other safe rigging principles and procedures;
- (2) Demonstrates the ability to utilize rigging materials and principles and;
- (3) Is capable of safely inspecting and performing rigging operations.

Rationale: Clearly defines the competencies/skills of a QR. ANYONE that performs any rigging task, must be trained appropriately.



15.D Slings

15.D.01 General. This section applies to slings used in conjunction with material handling equipment for hoisting. All slings shall be manufactured according to ASME B30.9.

Inspections.

(1) Slings, all fastenings and attachments shall be visually inspected **each day or shift when in use** by a CP.

(2) Annual inspections shall be performed by a CP and must be documented. Documentation must be available on site and available to the GDA upon request.

(3) Additional inspections shall be performed during sling use, where service conditions warrant. Damaged or defective slings shall be immediately removed from service.



15.D Slings

15.D.01.b Provides precise rigging practices that apply to most types of rigging.

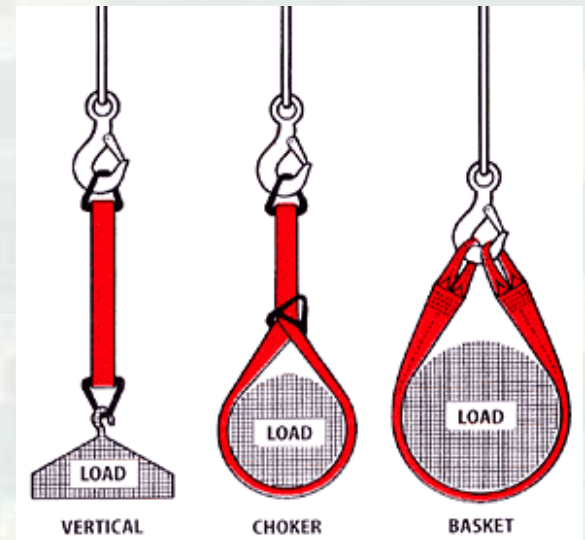

15.D Slings

15.D.01.c All slings shall be manufactured under ASME guidelines and must have an affixed durable permanent identification

Request Custom Smart Codes That Will Take You to Your Website or Request Other Custom Barcodes

Your Logos and Trademarks Displayed Professionally

Provides you with PERMANENT Warning Information

Permanent and highlighted Working Load Limits

Material and Date of Manufacturing

EVERY Sling, EVERY Component MADE IN USA

Request your Contact Information, Location, Web Address, Rig Number, Crane Number etc.

RATED CAPACITIES		
6,200 LBS	VERTICAL	Part No: EE2-902
4,960 LBS	CHOKER	Length: 5 FT 00 IN
12,400 LBS	V. BASKET	Width: 2 IN
NYLON	01/01/12	Serial No: 4996724-003

WARNING

- Must be properly trained before use.
- Failure to comply with this warning may result in sling failure and/or severe personal INJURY or DEATH.
- Inspect sling for damage before each use.
- Web slings shall always be protected from being cut by all corners, edges, protrusions or abrasive surfaces.
- Do not use sling above rated lifting capacity.
- Do not use sling if capacity tag is removed or not readable.
- Do not expose sling to temperatures above 194 degrees F (90 degrees C).
- Do not tie knots in sling webbing.
- Do not use sling if there are signs of cut webbing, heat or chemical damage, excessive wear, or other defects.
- Consult manufacturer's sling load chart for capacity reduction due to sling configuration and angle.
- Do not use nylon near acids. Do not use polyester near alkalis.
- If any of the above conditions exist, sling should be removed from service.
- Sunlight or ultra-violet light degrades the strength of slings.

MID-AMERICA RIGGING

405-235-0882

MADE IN USA



15.D Slings

e. Fabricated eye slings or endless loop slings using alloy steel wire rope clips or clamps for hoisting material or lifting are prohibited except where the application precludes the use of prefabricated slings. All slings fabricated using alloy steel wire rope clips or clamps shall be designed by a RPE for the specific application. > See Figures 15-1 and 15-2.

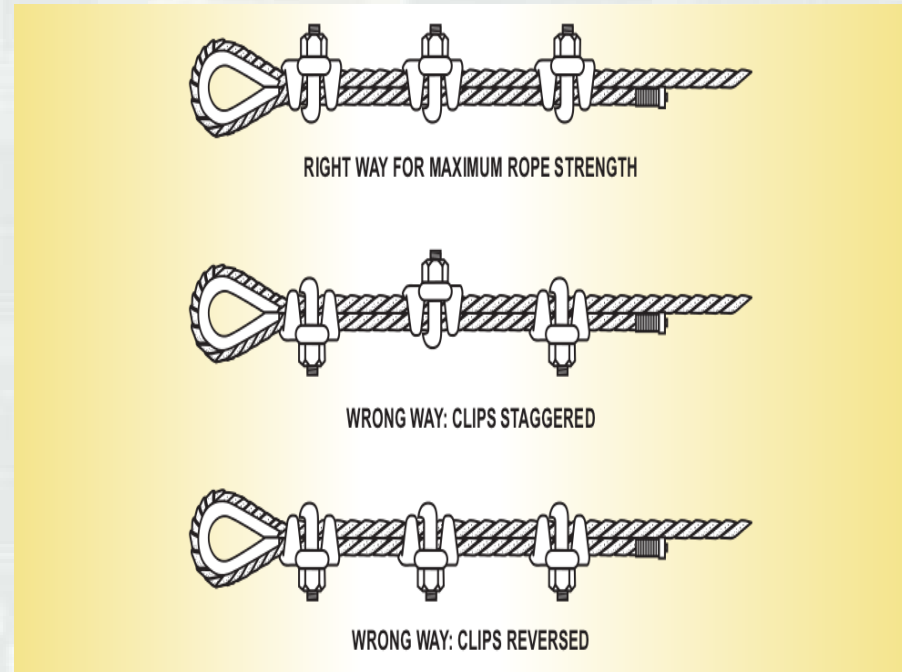

15.D Slings

15.D.02 Alloy Steel Chain Slings. Discusses size, inspections, and conditions warranting removal from service.

15.D.03 Wire Rope Slings. Provides specific elements that must be inspected by a Competent Person.

15.D.04. Metal Mesh Slings. Provides specific elements that must be inspected by a Competent Person.



15.D Slings

15.D.05 Synthetic Fiber Rope Slings. Prohibits the use of synthetic ropes when there is a potential to contact extreme temperatures.

15.D.06 Synthetic Web Slings. Provides specific elements that must be inspected by a Competent Person.

15.D.07 Synthetic Round Slings. Indicates specific information that must be marked on the sling before initial use and inspection elements that require the slings to be removed from service.



15.E – RIGGING HARDWARE

15.E.02 Rigging hardware shall not be painted once purchased. While the painting of rigging gear for identification is a common, USACE considers this an "unacceptable practice" and constitutes a "dangerous" condition.

Painting of hardware can potentially cover over defects creating a potentially unsafe condition.



15.E.06 - Shackles

15.E.06 All shackles shall be manufactured according to ASME B30.26.

- a. Only shackles marked by manufacturer with name or trademark of manufacturer (country only is not acceptable), WLL and size shall be used. Shackles shall be maintained by the user so as to be legible throughout the life of the shackle.

- d. Repairs and/or modifications may only be as specified by the manufacturer. Replacement parts, like pins, shall meet or exceed the original manufacturer's specifications.



15.E.07 - Hooks

15.E.07 Hooks. All hooks used for lifting or load handling purposes shall be manufactured according to ASME B30.10. > See Figure 15-3.

a. All hooks used for lifting or load handling purposes shall not be used in any other manner.

b. Hooks that show wear exceeding 10% or an increase in the throat opening of 5% (maximum of ¼ in (6mm)), or as recommended by the manufacturer, or any visibly apparent bend or twist from the plane of the hook shall be removed from service.



15.E.08 - Eyebolts

15.E.08 Eyebolts, Eye Nuts, Swivel Hoist Rings and Turnbuckles. All eyebolts, eye nuts, swivel hoist rings and turnbuckles shall be manufactured according to ASME B30.26.

a. WLLs shall be in accordance with the manufacturer's recommendation.

b. Each turnbuckle, eye nut and eyebolt shall be marked with name or trademark of the manufacturer (country is not acceptable), size or WLL and grade (for alloy eyebolts). In addition, each swivel hoist ring must also be marked to show torque value (excluding trench cover hoist rings).

Markings shall remain legible.





Section 16 – Load Handling Equipment

General:

16.A.01 The requirements of this Section are applicable to all load handling equipment (LHE) to include LHE, derricks, hoists and power- operated equipment that can be used to hoist, lower and/or horizontally move a suspended load.

Section 16 now applies to more than “cranes” in recognition of how the dynamics of the construction industry is changing. From Excavators to Telehandler, more material is used to...hoist, lower and/or horizontally move suspended loads. The Navy changed their nomenclature years ago to Weight Handling Equipment (WHE). We felt this is a better identifier of the equipment found in our work environment.



16.A - Exemptions – cont'd.

f. Powered Industrial Trucks (PIT's, i.e., Forklifts)/Telehandlers when configured to hoist and lower (by means of a winch or hook) and horizontally move a suspended (rigged) load are exempt from the requirements in 16.B.02 through 16.B.05 (crane operator certifications) only UNLESS this equipment is used to hoist/lift personnel. This activity is considered a Critical Lift and as such, requires a physical examination for the operator (per 16.B.05 and additional training per Section 16.Q. Rigger qualifications still apply, per Section 15.B. **See Section 16.Q for equipment-specific requirements;**



Section 16.A Exemptions – cont'd.

q. Material Delivery.

- (1) Articulating/knuckle-boom truck LHE that deliver material to a construction site when used to transfer materials from the truck crane to the ground, without arranging the materials in a particular sequence for hoisting.

- (2) Articulating/knuckle-boom truck LHE that deliver material to a construction site when the crane is used to transfer building supply sheet goods or building supply packaged materials from the truck crane onto a structure, using a fork/cradle at the end of the boom, but only when the truck crane is equipped with a properly functioning automatic overload prevention device. Such sheet goods or packaged materials include, but are not limited to: Sheets of sheet rock, sheets of plywood, bags of cement, sheets or packages of roofing shingles, and rolls of roofing felt.



Section 16.A Example of Exemption



BUILDING STRONG®

Section 16 - Exemptions – cont'd.

(3) This exclusion does not apply when:

(a) The articulating/knuckle-boom crane is used to hold, support or stabilize the material to facilitate a construction activity, such as holding material in place while it is attached to the structure;

(b) The material being handled by the articulating/knuckle-boom crane is a prefabricated component. Such prefabricated components include, but are not limited to: Precast concrete members or panels, roof trusses (wooden, cold-formed metal, steel, or other material), prefabricated building sections such as, but not limited to: floor panels, wall panels, roof panels, roof structures, or similar items;



Section 16.A Exemptions – cont'd.

(c) The material being handled by the crane is a structural steel member (for example, steel joists, beams, columns, steel decking (bundled or unbundled) or a component of a systems-engineered metal building.



16.A.02 – Certificate of Compliance

16.A.04 Contractors shall submit a Certification of Compliance (COC) for each piece of LHE prior to being brought on site. The COC shall be submitted to the GDA for acceptance. The COC states that the LHE and the rigging equipment meets applicable regulations. The COC shall be posted on the LHE. >
See Form 16-2, Certificate Of Compliance Form .



16.A.02 – Certificate of Compliance

<u>FORM 16-1</u>	
<u>Certificate of Compliance for LHE and Rigging</u>	
This certificate shall be signed by an official of the company that provides LHE/cranes and rigging gear for any application under this contract.	
Contracting Officer's Point of Contact: (Government Designated Representative)	Phone #:
Prime Contractor/Phone #:	Contract Number:
SSHO/QC:	Phone #:
LHE Manufacturer/Type/Capacity:	
LHE Operator(s) Name(s):	
<p>I certify that:</p> <ol style="list-style-type: none"> 1. The above noted LHE and all rigging gear conform to the EM 385-1-1, applicable OSHA regulations (host country regulations in foreign countries) and applicable ASME standards. 2. The operator(s) noted above has been trained, qualified and designated in accordance with the requirements in Section 16, EM 385-1-1 for the operation of the above noted LHE. 3. The operator(s) noted above has been trained not to bypass safety devices during LHE operations. 4. The operator(s), rigger(s) and company official (staff) are aware that immediate notification to the GDA of any incident or accident involving this equipment is required. 	
Company Official Signature:	Date:
Company Official Name/Title:	
Post on Crane/LHE. (In Cab and Contractor's Office for each LHE onto USACE Project/Property)	



Section 16.A.03 – Standard Lift Plan

16.A.03 Standard Lift Plan. All lifts must be planned to avoid procedures that could result in configurations where the operator cannot maintain safe control of the lift. A written standard lift plan (SLP) shall be prepared for every lift or series of lifts (if duty cycle or routine lifts are being performed). The SLP shall be developed, reviewed and accepted by all personnel involved in the lift. At a minimum, the following shall be addressed or use the non-mandatory Standard Pre-Lift Plan/Checklist shown in Form 16-1:

NOTE – From this point forward LIFT PLANS are required. Note that “A” plan could be developed for a series of lifts. You are now documenting what you were already doing.



Appendix xx
Pre-Lift Crane Checklist

DATE: _____ LOCATION: _____

TIME: _____ INSPECTED BY: _____

COMPETENT PERSON

NOTE: Applies to Cranes, Derricks, Hoists and Power-Operated equipment that can be used to hoist, lower and/or horizontally move a suspended load.

LOAD		Y	N
1	Weight and Center of Gravity (COG) has been Determined?		
2	Anything Inside / Outside the load that could shift during the lift?		
3	Determine if the load needs protection against damage from the rigging		
4	All anchor bolts, hold downs, or fasteners have been removed?		
5	Potential for binding – are load cells required to verify the load is free?		
6	Attachment points designed to take load weight?		
7	Is the load structurally capable of being lifted? (bending & twisting issues)		
8	A Pre-Lift Plan has been prepared IAW Section 16.A.02		
Comments:			

RIGGING

1	All rigging has been inspected by a Qualified Rigger?		
2	Determine the additional tensions based on sling angles.		
3	Are shackles correctly sized for the sling eye?		
4			
Comments:			

PERSONNEL

1	The roles, responsibilities and qualifications for personnel have been defined? (Operator, Lift Supervisor, Rigger, Signal Person)		
2	A Pre-Lift meeting has been conducted?		
3			
Comments:			

AREA PREPARATION

1	The location for the landing has been selected and prepared?		
2	Blocking and or Cribbing is available to set the load on?		
3	A travel path has been determined and cordoned off?		
4	Other personnel in the area have been notified of the lift?		
5	Have ground bearing support questions been addressed?		
Comments:			

You are documenting a process that you ARE going through every time you conduct a lift...now it's documented.

CRANE CONSIDERATIONS

1	Is the lift within the crane's rated capacity? (based on boom height, radius)		
2	Were boom deflections considered?		
3	Have all potential crane boom obstructions been identified?		
4	Have Environmental Considerations been addressed? (Wind, Weather-Lightning)		
5	Have electrical hazards been addressed (Overhead / Underground) <ul style="list-style-type: none"> - Clearance distances established? - Is a spotter required? - Public Utility contact required? 		
6	Crane swing radius properly barricaded and personnel advised of hazards?		
Comments:			

16.B.01 – Personnel Qualifications

b. LHE maintenance, inspection and repair personnel are permitted to operate the equipment only where all of the following requirements are met.

(1) The operation is limited to those functions necessary to perform maintenance, inspect the equipment, or verify its performance.



16.B.01 – Personnel Qualifications

(2) Lifting of loads by these personnel is allowed ONLY if they operate the equipment:

(a) under the direct supervision of a qualified operator (see 16.B.02), OR

(b) must read/review the operator's manual so that they are familiar with the operations, limitation, characteristics and hazards associated with the LHE being inspected, maintained, or repaired.

c. LHE maintenance, inspection and repair personnel covered by this section are exempt from the crane operator physical requirements identified in Paragraph 16.B.05.



16.B.02 – Crane Operator Requirements

16.B.02.a (1) Certification for all crane/hoist operators shall be achieved by successful completion of written and operational testing.

(2) Qualification of all crane/hoist operators shall be made by the employer after a review of the certification documents and an assurance that the operator(s) is familiar with the equipment to be operated (has adequate knowledge of crane safety requirements and manufacturer recommendations provided in the crane operator's manual). The employer then designates the operator(s) in writing for the equipment to be operated.



16.B.03 – Crane Operators

16.B.03 Crane Operator Certification, Qualification and Designation.

a. Option 1. Current certification by a Nationally Accredited Crane Operator Testing Organization.

(1) The operator's certificate must identify the type of equipment on which the operator was certified. Once the operator has obtained the certification, the employer must insure that the operator is qualified to operate a particular piece of equipment for that type and capacity and must designate this in writing.

Options 2-4 are same.

Option 2 "Audited Employer Program" – deadline extended 3 yrs by OSHA until 14 Nov 2017



CCO Certification Card FACT SHEET

Certification Number:
The eight (8) to nine (9) digit Certification Number appears in bold type and begins with a zero

Color Photo:
Look for photo embedded in laminated card

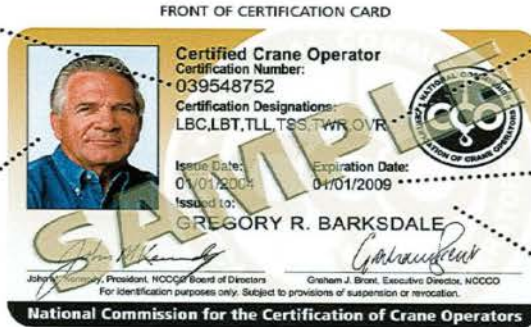

Certification Designations:
This area specifies what categories of crane the individual is certified in

Issue and Expiration Dates:
These dates tell you if the certification card is valid

NCCCO Logo:
Look for the ghosted logo and shading on the card

BACK OF CERTIFICATION CARD

Certification Code:
On the back of the card is an explanation of each certification category code

The National Commission for the Certification of Crane Operators (NCCCO) is a non-profit organization established to develop and administer examinations to test the adequacy of knowledge and skills of crane operators.

Certification designations are given in the following categories:

- LBT Lattice Boom Truck Cranes
- LBC Lattice Boom Crawler Cranes
- TSS Small Telescopic Boom Cranes (Fixed Cab)
- TLL Large Telescopic Boom Cranes (Swing Cab)
- TWR Tower Cranes
- OVR Overhead Cranes

Any questions regarding the status of the cardholder indicated on the front of this card should be addressed to:

The National Commission for the Certification of Crane Operators (NCCCO)
2750 Prosperity Avenue, Suite 505, Fairfax, VA 22031-4312
Ph: 703-560-2391; Fx: 703-560-2392; info@nccco.org

Verification:
If you have questions regarding the status of a candidate, please verify with our office using the contact info here

IMPORTANT

- NCCCO Certification Card is valid only in conjunction with a current DOT or NCCCO Medical Certificate
- Verify certification is current and in the appropriate crane categories
- Check card for irregularities
- Never accept a photocopy of a CCO card as proof of certification
- Contact NCCCO if in doubt!



0906

Should you check these?

16.B - Personnel Qualifications for Crane Operators

16.B.05 Operator Physical Qualifications/Examination. All crane/derrick operators shall be physically qualified to operate the equipment. Physical examinations for operators are required to be conducted every 2 years and any time a condition is observed that may impact safe operation. Written proof, signed by a physician [this term is intended to mean a Medical Doctor (M.D.) or Doctor of Osteopathy (D.O.)] stating that the operator has had a physical examination and meets the medical requirements set forth below shall be submitted to the GDA for acceptance prior to allowing an operator to operate the equipment.



16.B.05 – Operator Physical Qualifications

- 16.B.05 Crane operators shall have a current physician's certification, dated within the past 2 years, that states the operator meets the following physical qualifications:
 - 1-5 – no change
 - 6. No evidence that the operator is subject to seizures or loss of physical control. If evidence of this nature is found, it may be sufficient cause for disqualification. In such cases, specialized medical tests may be required to evaluate these conditions and determine their impact; and
 - 7. No Evidence of physical defects or emotional instability that could render a hazard to the operator, or that in the opinion of the examiner could interfere with the operator's performance. If evidence of this nature is found, it may be sufficient cause for disqualification. Specialized medical tests may be required to determine these conditions.



16.D INSPECTION CRITERIA FOR LOAD HANDLING EQUIPMENT (LHE)

- 16.D.01 Inspections of LHE shall be in accordance with this section, applicable ASME standards, OSHA regulations and the manufacturer's recommendations.
- 16.D.02 Records of all LHE tests and inspections shall be maintained onsite. Contractors shall make these records readily available upon request and, when submitted, they shall become part of the official project file.
16. D. 05 There are three general types of inspection: Shift, Monthly and Annual. Each inspection is explained in 16.D.06-08



16.D.10 Running and Standing Wire Rope Inspection.

a. Each Shift.

(1) The shift inspection must be documented and shall include the results of the inspection, name and signature of the CP who conducted the inspection and the date of the inspection.

(2) Documentation shall be maintained for a minimum of 12 months, or the life of the contract, whichever is longer.

b. Annual. At least every 12 months, wire ropes (running and standing) in use on equipment must be inspected by a QP in accordance with this Section, applicable ASME standard, OSHA regulations and the manufacturer's recommendations. Documentation is same as for Shift inspections above.



Section 16.F.02 - Operational Testing

- **ADDED:**
- Note: Adding/removing counterweights is not considered load controlling/load bearing.
- Note: Complete operational testing of the equipment after the replacement of wire rope is not required. However, a limited operational test shall be made prior to putting the equipment back into service.



Section 16.F.03 Load Testing

- (1) Hoist the test load to ensure that the load is supported by the crane and held by the hoist brake(s) for a minimum of 5 minutes;
 - (3) Boom the crane up and down within the allowable working radius for the test load. At the maximum radius, hold the load for a minimum of 5 minutes and insure there is no movement of the load;
- Note: Adding/removing counterweights is not considered load controlling/load bearing.
 - Note: Attaching/detaching a jib, which is an attachment, is not considered “reconfiguring or re-assembling” a crane and so does not require a load test. Installing or stowing the jib must be per manufacturer’s recommendations and a competent person shall document this action prior to operation.



16.I – Environmental Considerations

16.I.03 When lightning is observed, all LHE operations shall stop. A determination shall be made as to proximity to operation being performed. (Use a lightning detector or once lightning is seen, count the number of seconds until you hear thunder. Divide number of seconds by 5 to get the distance the lightning is away from you). If lightning is 10 miles away or less, work must stop until 30 minutes after the last audible thunder or visible flash of lightning. Plan work activities according to the latest weather forecast and be prepared to stop operations, until bad weather has safely passed. These actions shall be documented (daily report, crane operator's log book, etc.).



16.J Lattice, Hydraulic, Crawler-, Truck-, Wheel-, And Ringer-Mounted Cranes.

16.J.02.c. Blocking, cribbing and other means of securing shall be confirmed, verified and approved by a CP before assembly/ disassembly operations are allowed to proceed.





16.L Floating Cranes/Derricks, Crane Barges, and Auxiliary Shipboard-Mounted Cranes.

16.L.01 The requirements in this Section are supplemental requirements for floating LHE, pile drivers, drill rigs, man-lifts and land LHE on barges, pontoons, vessels or other means of flotation and auxiliary shipboard mounted cranes, unless otherwise specified.



16.L.03 LHE Manufacturer's Floating Service Load Chart.

- a. Manufacturer's Floating Service Load Chart. A LHE Manufacturer's Floating Service Load Chart shall be provided. The Load Chart shall be in accordance with all criteria from the selected standard in Section 16.L.02.
- (1) The Floating Service Load Chart shall provide a table of rated load vs. boom angle and radius.
- (2) The Floating Service Load Chart shall also provide the maximum allowable machine list and trim associated with the tabular loads and radii provided.



16.L.03 LHE Manufacturer's Floating Service Load Chart.

b. Floating Service Load Chart if Manufacturer's Floating Service Load Chart is not available, a floating service load chart may be developed and provided by a qualified RPE, competent in the field of floating cranes. The Load Chart shall:

- (1) Be in accordance with all criteria from the selected standard in Section 16.L.02;
- (2) Provide a table of rated load vs. boom angle and radius;
- (3) Provide the maximum allowable machine list and machine trim associated with the tabular loads and radii provided;
- (4) Be stamped by a RPE, qualified and competent in the field of floating cranes. The RPE, competent in the field of floating cranes shall, stamp and certify (sign) that the Naval Architectural Analysis (NAA) meets the requirements of Sections 16.L.03.



16.L.04 Stability During Lift Operation

- b. During lift operations, the stability of the floating LHE, or vessel and shipboard crane shall limit floating platform heel and trim such that the resultant LHE list and trim over the full range of LHE slewing angles are within the limits identified in the LHE Floating Service Load Chart.
- c. A minimum of 12 in (0.3 m) of freeboard shall be maintained during lift operations, over the full range of crane slewing angles.
- d. The entire bottom area of the floating platform shall be submerged for all lifts, over the full range of crane slewing angles.



16.L.05 Floating Service Naval Architectural Analysis (NAA).

a. The NAA shall evaluate the LHE on the floating platform. The LHE Manufacturer's Floating Service Load Chart (Section 16.L.03) shall be validated for:

- (1) The stability during lift operation (Sections 16.L.04.a through d), and
- (2) The machine list and trim limits for afloat service. The Load Chart shall be de-rated (reduced) as required to meet the requirements for stability during lift operation and for machine list and trim limits for afloat service.



16.L.05 Floating Service Naval Architectural Analysis (NAA).

- b. The NAA shall include the full 360° (degree) slewing range of the crane, unless specific slewing angle limits are identified.
- c. When deck loads are to be carried while lifting, the NAA shall incorporate the deck loading amount, location and deck load center of gravity, and sail area into the stability analysis.
- d. The NAA shall incorporate wind loading, into the heel and list calculations with a minimum wind speed of 40 mph (18 m/s).
- e. The NAA shall be stamped/certified by an RPE or qualified Naval Architect/Marine Engineer, competent in the field of floating cranes. The RPE or Naval Architect/Marine Engineer shall stamp and/or certify (sign) that the NAA meets the requirements of Sections 16.L.04, and 16.L.05.



16.L. 06 Floating Service Structural Analysis

- a. The floating platform structure shall be adequate for the loads applied from lifting over the full crane slewing range.
- b. For vessels which are not built for the application, a structural analysis shall be provided to document the structural adequacy of the floating platform in conjunction with applied LHE loads, for the lift amounts as developed in the NAA. Deck loads and environmental loads shall be applied as part of the structural analysis.



16.L. 06 Floating Service Structural Analysis

- c. Where established floating platform design structural capacities, such as allowable deck loads, are available, these may be used in support of the structural analysis.
- d. The structural analysis shall be stamped by an RPE, competent in the field of floating LHE. The RPE shall stamp and certify (sign) that the Floating Service Structural Analysis meets the requirements of Sections 16.L.04 and 16.L.05.
- e. The lift amounts developed in the NAA shall be reduced if the structural analysis shows insufficient structural capacity at the NAA loads. The amount of reduction shall be as required for the structural capacity.



16.L.20 – Standard Lift Plan

16.L.20 Standard Lift Plan. All lifts must be planned to avoid procedures that could result in configurations where the operator cannot maintain safe control of the lift. In addition to the requirements and criteria to be considered in Section 16.A.03 for a written Standard Lift Plan (SLP), the SLP for LHE on floating plant must also consider the following (The non- mandatory Standard Pre-Lift Plan/Checklist, Form 16-2 may be used)



16.R – Pile Driving Operations

16.R.01 Pile driver equipment shall be outfitted with a positive and negative restraint device to prevent accidental hammer disengagement (i.e., preventing the hammer from falling or uncontrolled rising out of the lead, as well as preventing contact with head block or sheaves, if so equipped).



16.R

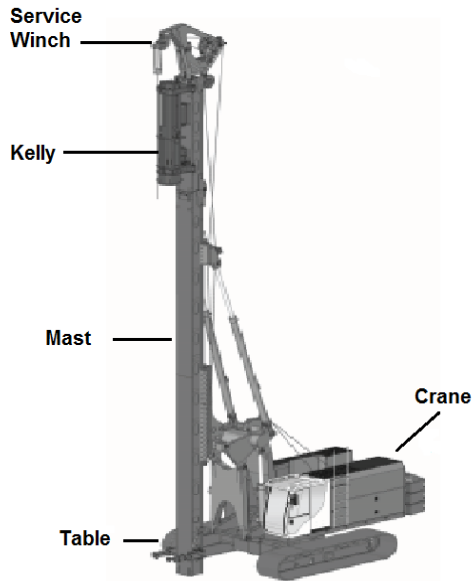
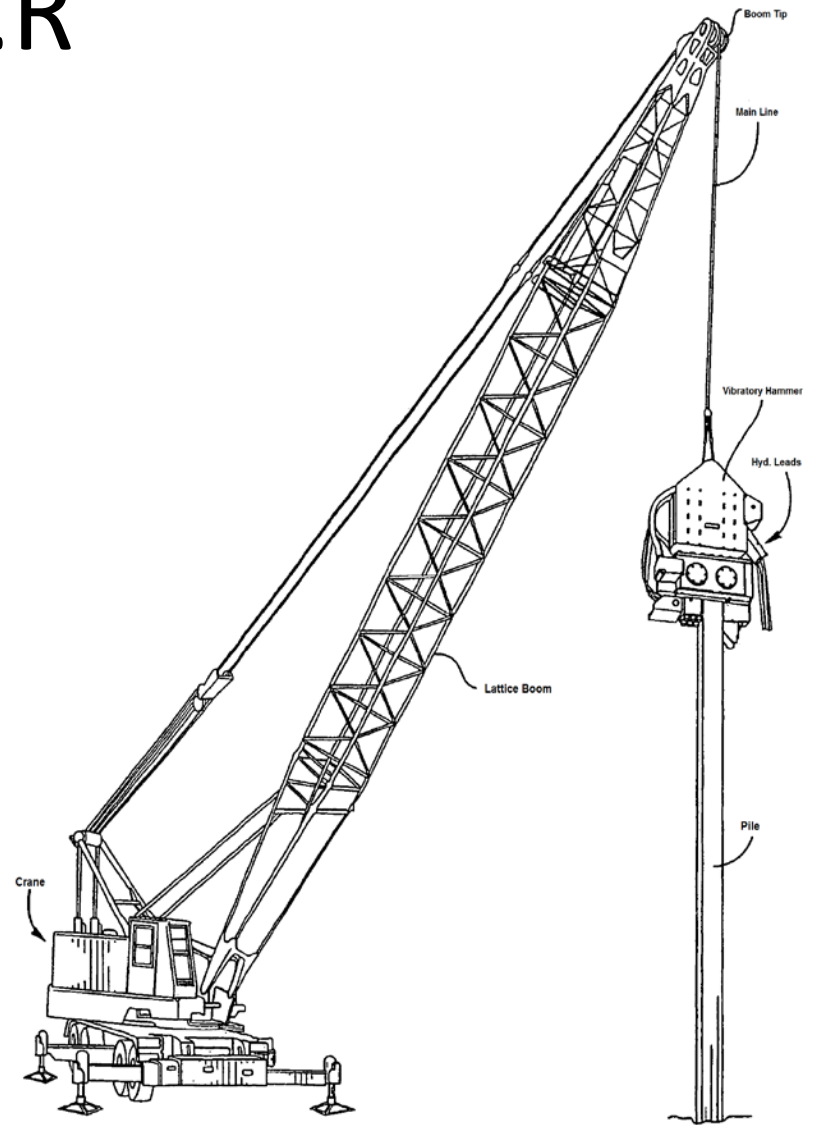

Figure 16-2

Dedicated Pile Driver



Crane Supported Pile Driver

16.R – Pile Driving cont'd.

16.R.07 Pile Driving leads.

a. Pile driving leads shall be assembled using only the approved fasteners and torque values as required by the manufacturer. The leads shall be of adequate size, length, and strength to safely accommodate the weight and length of the pile driving hammer, the pile to be driven, and the position (vertical or on a batter) in which they will be used.

f. A blocking device, capable of supporting the weight of the hammer, shall be provided for placement in the leads under the hammer at all times while employees are working under the hammer.

Exception: Where it is necessary for an employee to momentarily lean through the leads to guide a pile under the hammer, it is not required that the pile hammer be blocked in the leads.



16.R – Pile Driving cont'd.

g. A minimum weekly documented inspection of the pile driving leads shall be conducted. If found to be unsafe, or whenever a deficiency that affects the safe use of pile driving leads is observed, they shall be immediately taken out of service and their use prohibited until unsafe conditions have been corrected.

h. Swinging leads shall have fixed ladders or have bracing located such that its configuration will serve as adequate ladder rungs Fixed leads shall have fixed ladders and if so equipped, the decked landings shall have guard rails, intermediate rails, and toe boards. Fixed ladders or stairs shall be provided for access to landings and head blocks.



16.R – Pile Driving cont'd.

16.R.07.i. Fixed leads shall:

- (1) have fixed ladders and if equipped with decked landings, shall have guardrails, intermediate rails, and toe boards. Fixed ladders or stairs shall be provided for access to landings and head blocks.

- (2) be provided with guardrails or Personal Fall Protection Systems, to include Certified Anchorages, to provide fall protection for any workers exposed to falls of 6 ft (1.8 m) or greater, for work over water, over machinery, or over dangerous operations per EM 385-1-1, Section 21.

- (3) have a crane boom tip connection designed by a RPE that is familiar with the ASME B30 standards.



16.S Hydraulic Excavators, Wheel/Track/Backhoe Loaders Used to Hoist Loads with Rigging.

16.S.02 Hydraulic excavating equipment shall not be used to hoist personnel. The riding of personnel on loads, hooks, hammers, buckets or any other hydraulic excavating equipment attachment is prohibited.

16.S.03 Excavators used with attachments such as drill rigs, pile driving equipment, etc. shall require training specific to that operation for the operator.



16.T – LHE- Supported Personnel (Work) Platforms.

16.T.02 Only LHE with power-operated up and down boom hoists and load lines shall be used to support work platforms. The use of machines having live booms is prohibited (i.e., friction cranes). Platforms shall be lowered under power and not by the brake.

16.T.13 Traveling – equipment other than derricks,

- a. Hoisting of personnel while the crane is traveling is prohibited, except for equipment that travels on fixed rails or it is demonstrated that there is no less hazardous way to perform the work. This does not apply to rubber-tired equipment.





Section 17 - Conveyors

The major change to section 17 is:

Organization: Section “A” will be General Rules,
“B” will be Operation, and
“C” will be Training

All others are minor and mostly informational



Section 18 – Vehicles, Machinery and Equipment

Added new:

18.A.01 Every person operating machinery and mechanized equipment, ATVs, UVs or other specialty vehicles, shall be properly trained (as described in this Section), qualified (license/certificate/permit) and designated by the employer in writing to operate such equipment.

Rationale: goal is to insure people are trained (technically), qualified (means operationally skilled and competent on the equipment and designated (means in writing by authorized person.



Section 18.B – Guarding and Safety Devices

18.B.01:

- d. Commercial cargo vehicles...intended for use on public highways with a normally clear view through the rear window are not required to have back-up alarms. If the view to the rear is temporarily obstructed by a load or permanently blocked by a utility/tool box or other modification, then a signal person may be used, if the value outweighs the risk as determined by an AHA. In lieu of a signal person, a back-up alarm must be installed.

Rationale: Signal persons are at risk. Use is based on risk assessment.



Section 18.B – Guarding and Safety Devices

18.B.02 A warning device shall be provided where there is danger to persons from moving equipment, swinging loads, buckets, booms or similar. A signal person may be used in lieu of a warning device if the value outweighs the risk, as determined by an AHA.

Rationale: Signal persons are at risk. Use is based on risk assessment.



Section 18.G.29 – PITs, Forklifts and Telehandlers

Additions in this section:

- to insure properly trained, qualified, designated operators;
- if equipment used with rigging or hooks to lift loads – directs them to Section 16.V as this is now LHE
- Identifies training criteria



Section 18.G.29 – PITs, Forklifts and Telehandlers

Additions in this section:

- i. Multi-purpose machines, material handling equipment (i.e. Rough-Terrain Forklifts, Lulls, etc.), and construction equipment used to lift loads suspended by rigging equipment shall:
 - have proof or authorization from the manufacturer that the machine is capable of making lifts of loads suspended by rigging equipment;
 - demonstrate that the equipment is properly configured to make such lifts, and
 - the machine/equipment must be equipped with a load chart.



Section 18.G.29 – PITs, Forklifts and Telehandlers

- j. Contractor must provide certification that the operator is trained, qualified and designated for the operation of the machine (multi-purpose, material handling and construction equipment) being utilized to lift loads suspended by rigging equipment.

Rationale: Anyone using equipment with rigging/hooks to lift a load is now operating Load Handling Equipment per section 16. This requires different set of skills form normal operation of this equipment. Insuring that personnel are prepared to perform this type of work on this equipment.



Section 18.G.30 – Floating Equipment

New Section. Any equipment placed in floating mode is now addressed and discusses evaluation by QP for safe placement, transport and operation; whether the equipment can be safely operated within the manufacturer's operating procedures; what to do if there are not manufacturer's procedures available;

Pushes reader to Section 16.L if this equipment is used in conjunction with rigging to lift a load, then it is LHE.



Section 18.G.30 – Floating Equipment

Rationale: All equipment operated from a floating base may not be allowed to operate in this capacity. This determination must be made prior to operation to insure overload conditions do not occur, adequate flotation is used and proper personnel qualifications exist to prevent tipping of equipment, barge or both does not occur.



Section 18.H – Drilling Equipment

18.H.03 AHA development. Changed to include AHA requirement “prior to initiating rock, soil, and/or concrete drilling operations, not just earth drilling. New items added to required information included on AHA.

18.H.04 – describes additional info drill crews shall be trained on.

18.H.05 Drilling equipment shall be equipped with two easily accessible emergency shutdown devices, one for the operator and one for the helper. Added a-c details below:

- a. Only one emergency shutdown switch is required on a pier hole rig.
- b. Rigs must be shut down before any helpers enter a barricaded area.



Section 18.H – Drilling Equipment

18.H.05

c. Auger heads must be in the hole or a cover placed over the hole before workers enter the barricaded area.

Note: If infeasible due to type of drill equipment being used, a risk assessment shall be performed by a Competent Person (CP), and documented in the AHA as to why this requirement is not practical. Identification of additional precautions and/or controls shall be identified to insure an equal level of safety is being accomplished.

Rationale: Our drilling operations include various types, not just earth/geotechnical drilling. Requirements now reflect that fact. We had GREAT input from industry on these changes.





Section 19 – Floating Plant and Marine Activities

19.A.07 – Safe Practices.

- d. Swimming and/or diving shall be prohibited for all personnel, except certified divers in the performance of their duties, unless necessary to prevent injury or loss of life.

Rationale: To prevent diving other than by certified divers. To provide requirements to safe-side this hazardous operation that is being performed.



Section 19 – Floating Plant and Marine Activities

19.A.07 – Safe Practices.

- e. Wading is permitted only when there are no severe underwater hazards such as sudden drop-offs, heavy surf above 3 ft (1 m), dangerous aquatic life, etc. Personnel wading shall wear an approved PFD and shall be monitored by personnel who are nearby and equipped to conduct a rescue if needed. Wading shall be discontinued when the person's feet cannot easily touch bottom, regardless of depth.

Rationale: To prevent diving other than by certified divers. To provide requirements to safe-side this hazardous operation that is being performed.



Section 19.G - Dredging

19.G.03. Added paragraph:

- c. Pipelines shall be marked with the owner's name for positive identification in the event of loss (adrift) or damage to vessels operating in the area.

Rationale: Positively identifies the owner.



Section 19.G - Dredging

19.G.03. Added paragraph:

Added additional requirements to 19.G.09 Dredge disposal sites based on mishaps that have been incurred.

- d. Amphibious excavators will only be operated in accordance with the manufacturer's operating instructions. A copy of the operator's manual will be readily available on the equipment.
- e. Lighting. Lighting shall be provided as required by Section 7 of this manual. The minimum lighting level in the vicinity of the disposal site shelter (dump shack) shall be 5 foot-candles.



Section 20 - Pressurized Equipment and Systems

Section 20.D Compressed Gas Cylinders

Para 20.D.03. f: Cylinders shall be stored in accordance with 20.D.03, unless it is reasonably anticipated that gas will be drawn from the cylinders within 24 hours and thus considered in service.

Important to differentiate storage from “in service”, as it is common to find oxygen and fuel gas cylinders in a ready-to-use state that should actually be in storage. Using OSHA’s definition of when storage requirements are to be followed.



Section 20 - Pressurized Equipment and Systems

Section 20.D.09

Para 20.D.09 Compressed gas cylinders transported by crane, hoist, or derrick shall be securely transported in cradles, nets, or skip pans, and never directly by slings, chains, or magnets, unless the cylinder manufacturers' handling instructions specifically allows for handling cylinders otherwise.

Agree that some exceptions should be allowed, if the manufacturer provides adequate lifting points and allows for handling of specific cylinders, per specific manufacturer instructions.



Section 21 - Fall Protection Major Changes and Rationale

21.A.05 Fall protection is **required** for employees exposed to fall hazards while conducting inspection, investigation or assessment work **during construction activities**.

21.A.06 Fall protection **may not be** required when conducting inspection, investigation or assessment work **more than 6 ft (1.8 m)** away from an unprotected edge of a roof, **before start of construction or after construction work is complete**.

When the roofing inspection and investigation work is conducted within 6 ft from the unprotected edge, fall protection is required. An Activity Hazard Analysis (AHA) shall be developed/reviewed by a CP for this activity and submitted for GDA review and acceptance.



Fall Protection - Major Changes and Rationale

21.A.07 Fall protection is **required** when conducting inspection and investigation work **during maintenance evolutions** (i.e. inspecting or maintaining HVAC or other equipment on roofs).

- 1. This clarifies that there are specific situations where no engineered system is needed.*
- 2. **Rationale:** Inspection of the equipment on roofs during maintenance work falls under the OSHA general industry standard, 29 CFR 1910 -- FP is required.*



Clarification for 21.A.06

FP is required in the Control Zone when conducting inspection and investigation work of roofs

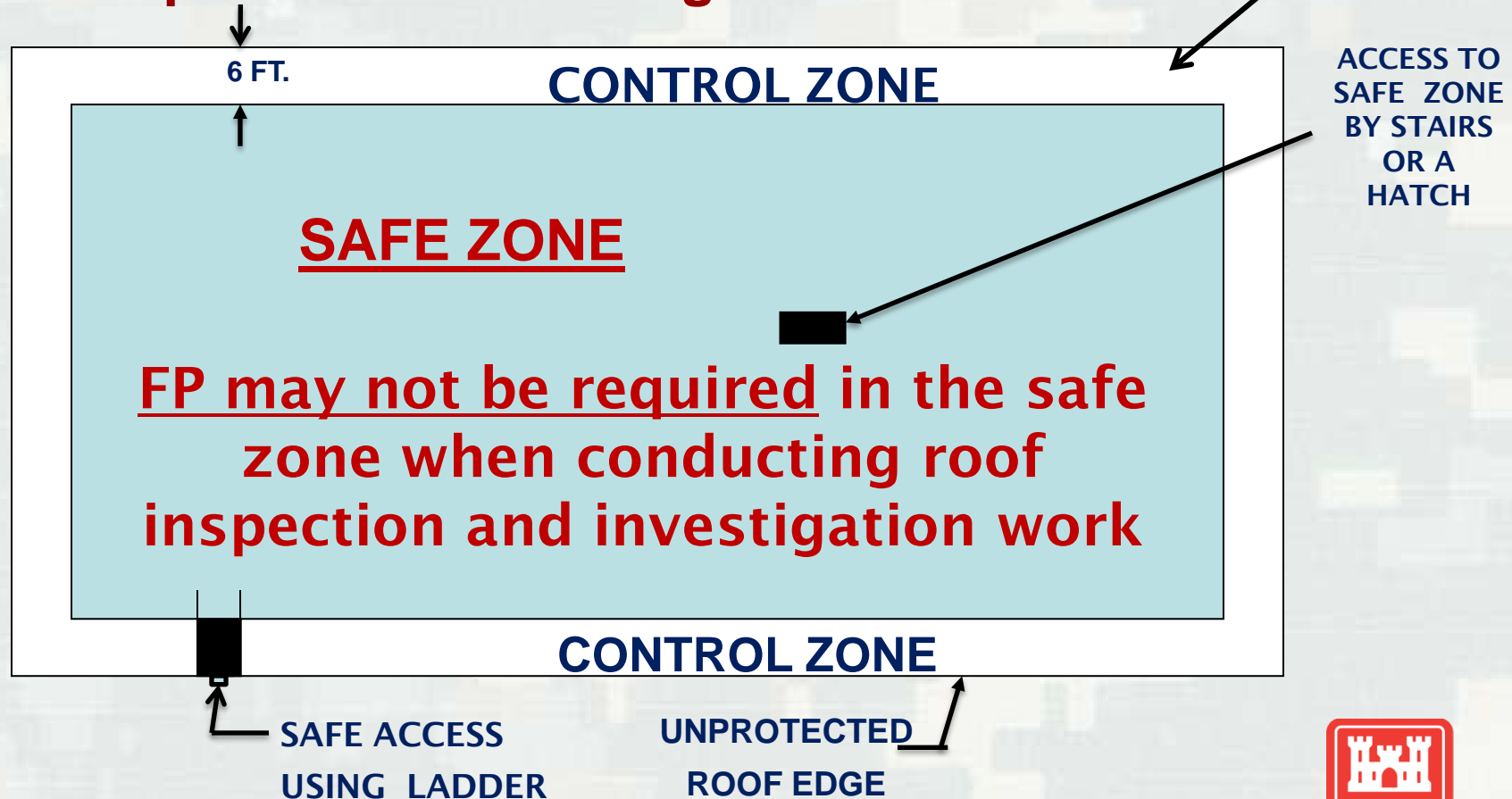

FP may not be required in the safe zone when conducting roof inspection and investigation work



Section 21 - Major Changes and Rationale Excavation

21.A Added a note referring to section 25.A.02 for excavation fall protection.

25.A.02 will state:

When persons for the purpose of inspection/testing will be in or around an excavation that is deeper than 6 ft (1.8m) but less than 20 ft (6.1m) or contains hazards (e.g., impalement hazards, hazardous substances) shall be provided with fall protection IAW Section 21.



Section 21 - Major Changes and Rationale Excavation

EXCEPTION: The Designated CP may exempt the use of fall protection for inspectors/supervisors provided those individuals are not exposed to hazards within **24 inches** of edges, the excavation contains no hazards and the individual(s) stay a minimum of 24 inches from the excavation edge.

Rationale. Provides practical guidance for work around excavation edges where fall protection may be impractical.



Section 21 - Major Changes and Rationale

21.B. New section that clarifies and identifies the specific roles for those engaged in a fall protection program.

21.B.01 Program Manager

21.B.02 Qualified Person

21.B.03 Competent Person

21.B.04 End User

21.B.05 Competent Rescuer

21.B.06 Authorized Rescuer

Rationale. Definitions were in Appendix Q but there were numerous queries from the field as to what specifically were the duties.





Section 21 - Major Changes and Rationale

21.C Included training requirements for all personnel involved in the FP program, as prescribed in Z359.2 Standard and conforming with Z490.1 standard.

21.C.04 Competent Person Training.

a. Effective the date of this manual, acceptable Competent Person for Fall Protection training shall be a **minimum of 24 hours, with a combination of formal classroom training and practical application**. Training will be performed by a competent person trainer or a qualified person trainer conforming to the requirements of ANSI/ASSE Z490.1, Criteria for Accepted Practices in Safety, Health and Environmental Training.

b. Competent person refresher training shall be conducted at least every two years to stay current with the fall protection and rescue educational industry requirements or when new fall protection systems are used or installed of new fall hazards are encountered.





Section 21 - Major Changes and Rationale

Standardizes training for Competent Persons. Audits of on-line and classroom Competent Person training courses that are as short as 2 hours in length do not cover the minimum training requirements listed in ANSI/ASSE Z359 Fall Protection Code. Employees can obtain 8-16 hours of formal training from a variety of vendors both on-line and class room and the 8 hours of practical can be conducted by the vendor or internally by a qualified fall protection trainer, focusing on local processes and equipment.



Section 21 - Major Changes and Rationale

POSITION TITLE	TYPE OF TRAINING (Reference ANSI/ASSE Z359.2)	LENGTH AND REFRESHER All training shall be documented. <i>Refresher training hours are for Corps only. Contractors shall follow requirements of ANSI Z359.2</i>
Fall Protection Program Manager	<ul style="list-style-type: none"> - Working knowledge of current fall protection regulations, requirements, standards, equipment and systems. 	<ul style="list-style-type: none"> - 1 hour of initial and refresher annually covering fall protection and rescue. Can be informational meetings or training sessions.
Qualified Person (QP) for Fall Protection	<ul style="list-style-type: none"> - Trained by a QP Trainer in proper inspection, assembly and use of fall protection equipment and systems that they encounter in their work as a QP. 	<ul style="list-style-type: none"> - By Professional training, qualification, or certification - 1 hour annual refresher. Can be informational meetings or training sessions.
Competent Person (CP) for Fall Protection	<ul style="list-style-type: none"> - Trained by a Competent Person or Qualified Person for Fall Protection trainer. 	<ul style="list-style-type: none"> - Initial 24 hours of a combination of formal and practical, documented. - 2 hours of annual refresher. Can be informational meetings or training sessions, or a combination there -of.
End User	<ul style="list-style-type: none"> - Trained by Competent Person for Fall Protection who is qualified in delivering fall protection training. 	<ul style="list-style-type: none"> - 2-8 hours or as appropriate initial training - 1 hour annual refresher.
Authorized Rescuer	<ul style="list-style-type: none"> - Trained by a Competent Rescuer 	<ul style="list-style-type: none"> - 2-8 hours or as appropriate - 1 hour annual refresher
Competent Rescuer	<ul style="list-style-type: none"> - Trained by a Competent Rescue Trainer 	<ul style="list-style-type: none"> - 2-8 hours or as appropriate - 1 hour annual refresher
Supervisors of End Users and other applicable employees	<ul style="list-style-type: none"> - FP awareness training - Familiarization with SOPs - Local program requirements - Proper inspection and record keeping - Proper anchoring and tie-off techniques 	<p>Local Training plan/briefing, and/or instruction, SOP or Web Based Training</p> 

Section 21 - Major Changes and Rationale

21.F.01.e Guardrails

Included requirement for another guardrail system; Commercial off-the-shelf engineered guardrail system (made of webbing, straps, etc.).

Commercial off-the-shelf reusable system.



Section 21 - Major Changes and Rationale

21.F.05. Existing parapet walls. Any combination of 30 inches or more in height plus width that equals 48 inches or more is acceptable.

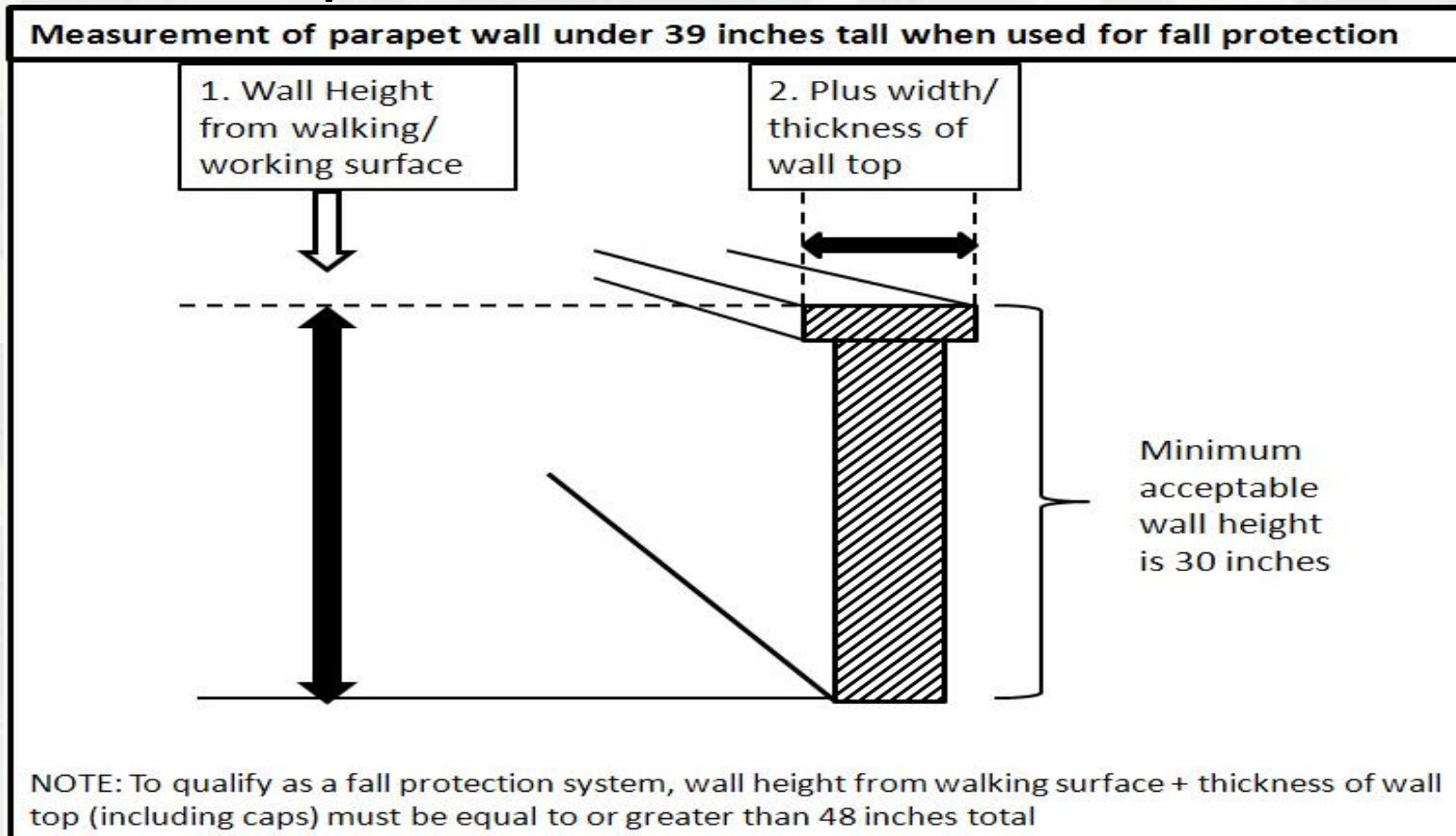

Section 21 – Fall Protection

21.1.05 Personal Fall Arrest System (PFAS) consists of full body harness, connecting means, and an anchorage system.

Note: All PFAS shall meet the requirements contained in ANSI Z359, Fall Protection Code, to include fall restraint and positioning systems.

- a. PFAS are generally certified for users within the capacity range of 130 to 310 lbs (59 to 140.6 kg) including the weight of the worker, equipment and tools.
 - (1) Workers shall not be permitted to exceed the 310 lbs (140.6 kg) limit unless permitted in writing by the manufacturer.
 - (2) For workers with body weight less than 130 lbs (59 kg), a specially designed harness and also a specially designed energy absorbing lanyard shall be utilized which will properly deploy if this person was to fall.

Rationale: Reorganized the section for better flow.



Section 21 – Fall Protection

21.1.06.a.(3). All full body harnesses shall be equipped with Suspension Trauma preventers such as stirrups, relief steps, or similar in order to provide short-term relief from the effects of orthostatic intolerance.

The cost of adding these devices is minimal, \$20-30, but the added benefit of preventing trauma from being suspended is extremely important in protecting workers.





**Strap to prevent suspension
trauma
(use 2 straps, one for each leg)**



BUILDING STRONG®

Section 21 – cont'd.

21.I.07.b.(6) note. > **Effective 2 years** from the date of publication, all energy absorbers used shall be equipped with deployment indicator.

Energy Absorber equipment currently being manufactured in compliance with the Z359 Fall Protection Code is being equipped with deployment indicators. The 2 year period is to allow continued use of equipment on-hand prior to mandating replacement, which should fall in line with typical 5 year life-spans of energy absorbers.



21.I.05. Calculating Fall Distance. Drawing added to aid field.

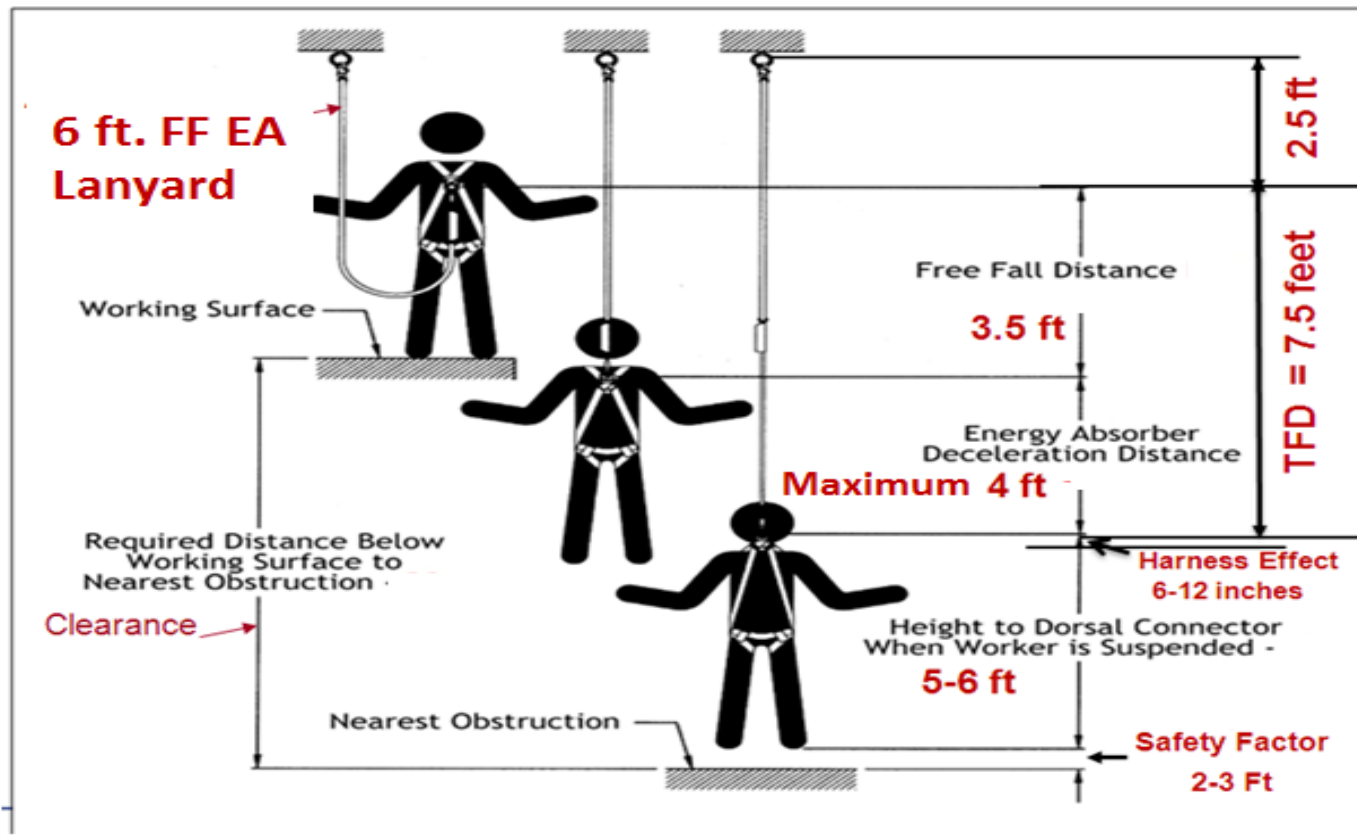

Section 21 – Fall Protection

21.1.06.b. Lineman's equipment (electrically rated harnesses).

The full body harness used around high voltage equipment or structures shall be an industry designed "linemen's FP harness" that will resist arc flashing and shall meet the ASTM F887 and ANSI Z359 standards and the equipment must bear a label or similar stating such .

Previous language did not allow exposed metal D-rings. Some manufacturers such as Miller have insulated metal components but still pass the ASTM standard.



Section 21

21.1.07.d **Self Retracting Devices.** The SRDs shall meet the requirements of the ANSI/ASSE Z359 Fall protection Code. (1) Self-retracting lanyard (SRL) is a device mounted or anchored such that possible FF distance is limited to 2 ft (60 cm) or less and the average arrest force shall not exceed 1,350 lbs (6 kN) or a maximum peak force of 1,800 lbs (8 kN). The device is only used for vertical applications.

(2) Self-retracting lanyard **with leading edge** capability (SRL-LE) is designed for applications where during use the device is not necessarily mounted or anchored overhead and may be at foot level and where the possible free fall distance is up to 5 ft (1.5 m). The device is equipped with energy absorber to withstand impact loading of the line constituent with a sharp or abrasive edge during fall arrest and for controlling fall arrest forces on the worker.

Aligning with the ANSI/ASSE Z359 Fall Protection Code



Section 21

21.K.04 Self-Propelled Elevating Work Platforms/Scissor Lifts: Scissor lifts shall be equipped with standard guardrails. In addition to the guardrail provided, the scissor lift shall be equipped with anchorages meeting the ANSI Z359, Fall Protection Code. Scissor lifts not equipped with anchorages shall not be used. A restraint system shall be used in addition to guardrails and the lanyards used with the restraint system shall be sufficiently short to prohibit workers from climbing out of, or being ejected from the platform. Lanyards with built-in shock absorbers are acceptable. The use of a self retracting device is acceptable if permitted in writing and used in accordance, and strict compliance, with the manufacturer instructions. Determination of using a self retracting device in scissor lifts shall be made in writing by a Qualified Person for Fall Protection and submitted as part of the fall protection and prevention plan. At no time will workers be allowed to climb on or over the guardrails.



Section 21

- *Added 21.K.04 “Self-Propelled “to title of section to clarify that the section applies to scissor lifts and similar that meet the ANSI A92.6 standard.*
- *Allowed the use of SRLs for restraint when authorized by a Qualified Person for Fall Protection.*
- *Allow lanyards with built-in shock absorbers for restraint.*
- *Scissor lifts not equipped with approved anchorages are banned.*



Section 21

21.K.05 Aerial Work Platforms (Boom Supported Platforms and Vehicle Mounted Rotating and Elevating Aerial Devices) Workers shall be anchored to the basket or bucket in accordance with manufacturer's specifications and instructions (anchoring to the boom may only be used when allowed by the manufacturer and permitted by the Competent Person for fall protection). Lanyards used shall be sufficiently short to prohibit worker from climbing out of basket. Lanyards with built-in shock absorbers are acceptable however self-retracting lanyards are not acceptable. Tying off to an adjacent pole or structure is not permitted unless a safe device for 100% tie-off is used for the transfer.

Banned SRLs but allow shock absorbers to clarify this section.



Boom Supported Platforms (ANSI A92.5)

Figure 3
Boom-Supported Elevating Work Platform

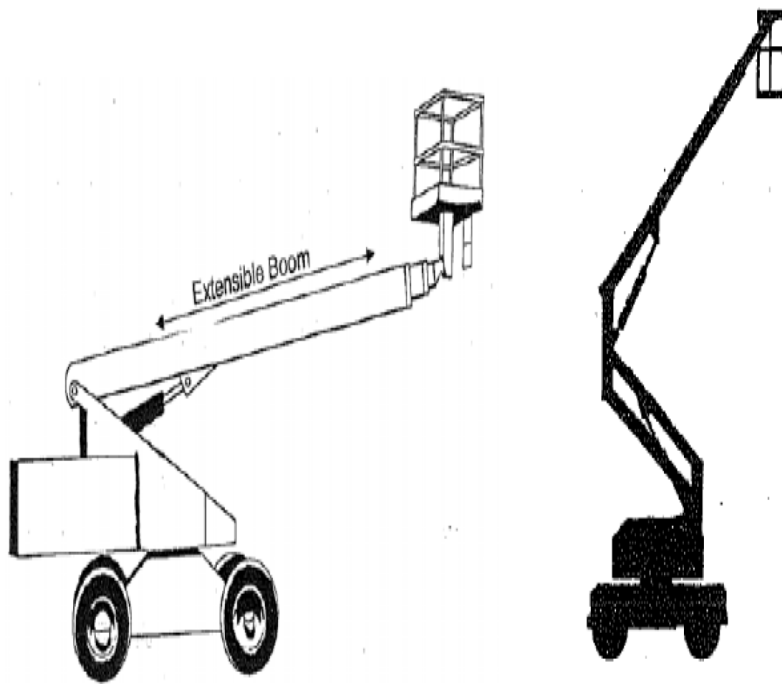

Vehicle Mounted and Elevating Aerial Devices (ANSI A29.2)

Figure 1
Vehicle-Mounted Elevating Work Platform

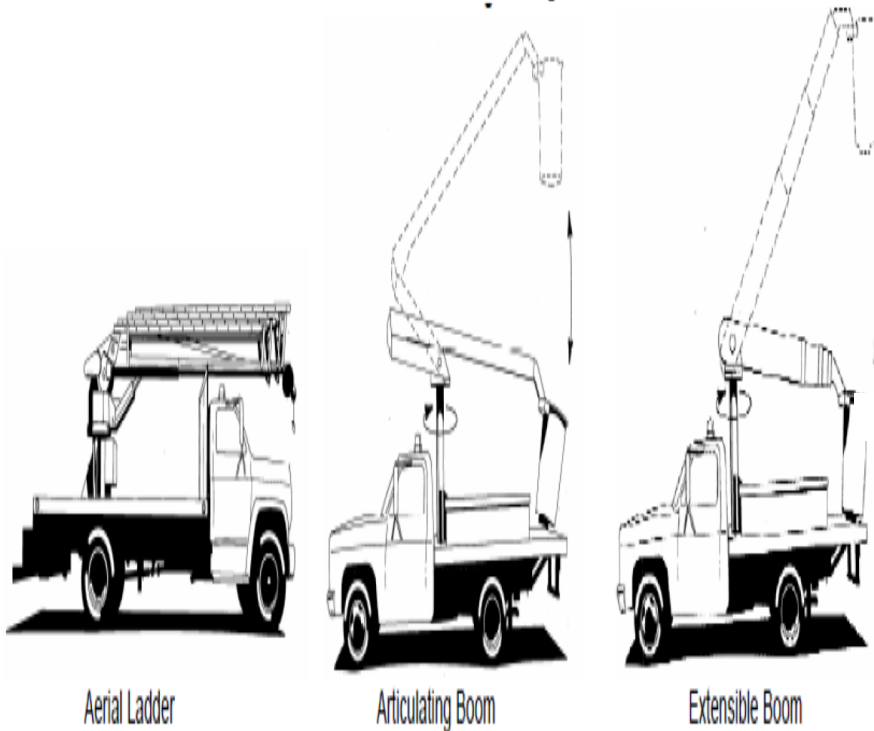

Major Changes and Rationale

- Added a new section to address manually propelled elevated work platforms (see next slide for examples).

 - 21.K.06 Manually Propelled Elevating Work Platforms per ANSI/SIA A92.3: The platform shall be equipped with standard guardrails. **If the platform is equipped with anchorages** meeting the ANSI Z359 Fall Protection Code, a restraint system shall be used in addition to the guardrails. Lanyards used with the restraint system shall be sufficiently short to prohibit workers from climbing out of, or being ejected from the platform. Lanyards with built-in shock absorbers are acceptable however the use of a self retracting device is **not** acceptable. The platform shall not be occupied when moved and at no time will workers be allowed to climb on or over the guardrails.
-
- *Fall restraint shall be used if equipped with anchorages*
 - *Self-retracting devices are not allowed as restraint*



Manually Propelled Elevating Work Platforms – ANSI/SIA A92.3

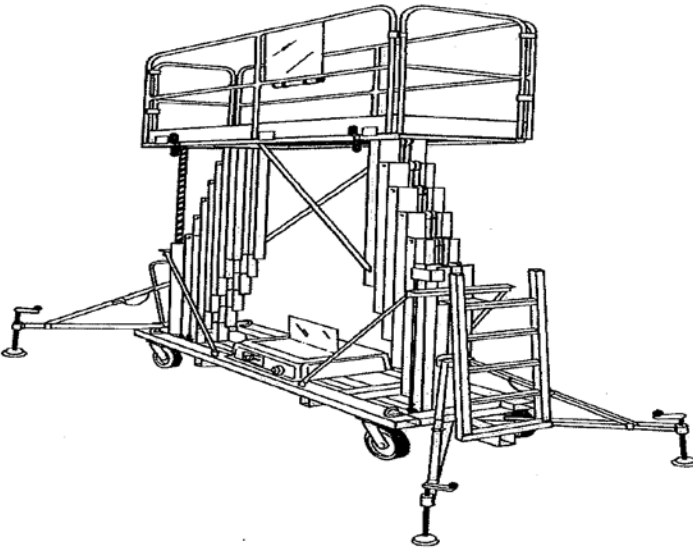
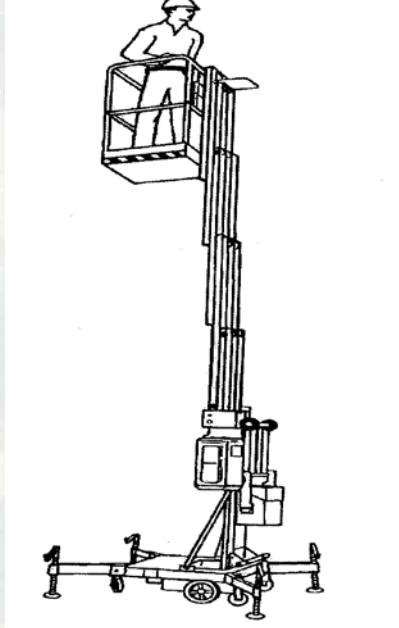

Section 21 – Fall Protection

21.L.07. A Designated Area is used as a FP method during maintenance work (i.e. inspecting or maintaining HVAC equipment) on roofs. The requirement for the Designated Area is identical to WLS. In addition a 100% transition is required from the access point on the roof to the Designated Area.

Rationale: *Warning line is used during construction work (29 CFR 1926.500), while designated area is used during maintenance work (29 CFR 1910 general industry standard).*



Clarification for 21.L.07

100% transition is required from the ladder to the designated area

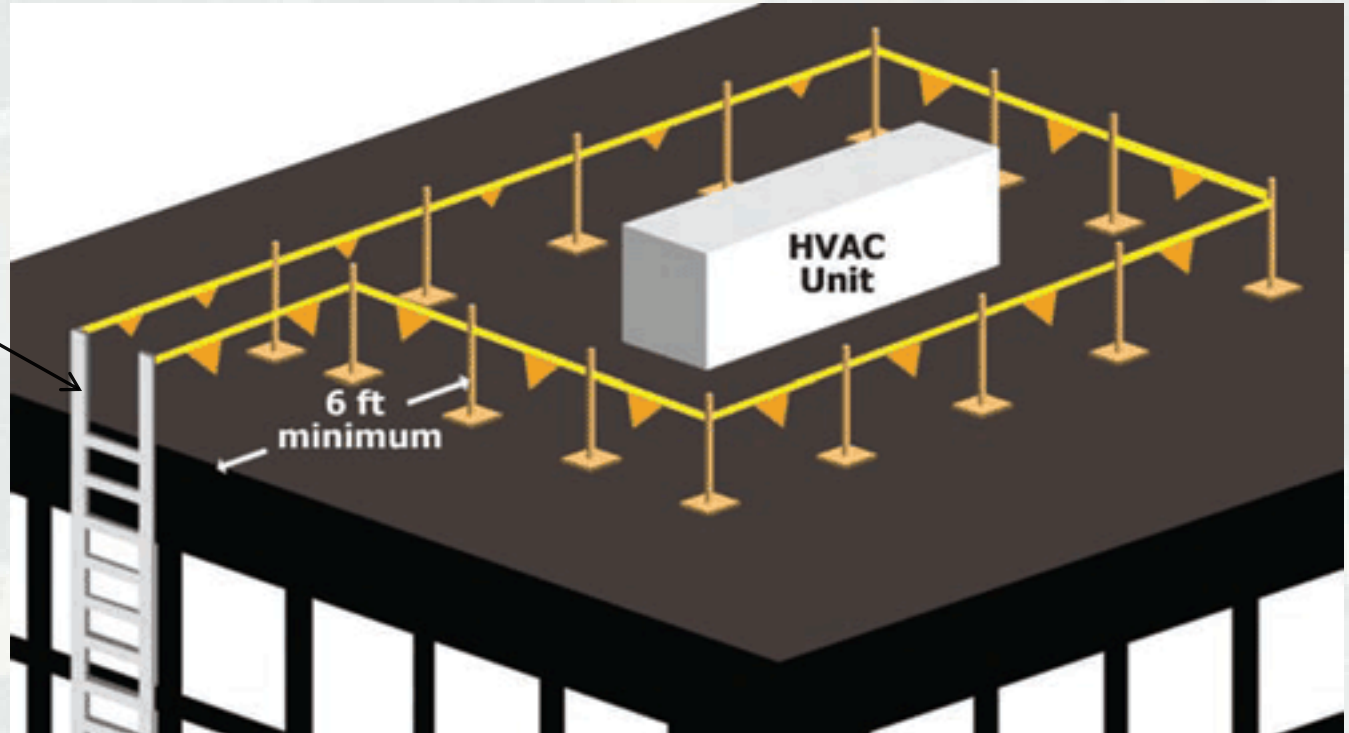

- Designated area is also used for inspecting mechanical equipment (Other than roof inspections)



Section 21 – Fall Protection

21.M SAFETY MONITORING SYSTEM (SMS). The use of a SMS as a fall protection method is prohibited.

There has been confusion on the part of some in the way the 2008 version was worded that the Corps “required” a SMS in some situations.



Section 21 – Work Over Water

21.0 WORK OVER WATER.

Added a note stating: If utilizing PFDs with full body harness, the full body harness shall be worn under the PFD. The type of PFD used shall not interfere with proper use of a full body harness and lanyard.

Rationale: There has been confusion on whether the harness would be worn under or over the PDF. Harness manufacturers require the harness to be worn under a PFD to function properly.



21.0 WORKING OVER OR NEAR WATER

ADDED A FLOW CHART TO CLARIFY THIS SECTION

Fall Protection (FP) vs. Personal Flotation Device (PFD) Use When Working Over or Near Water

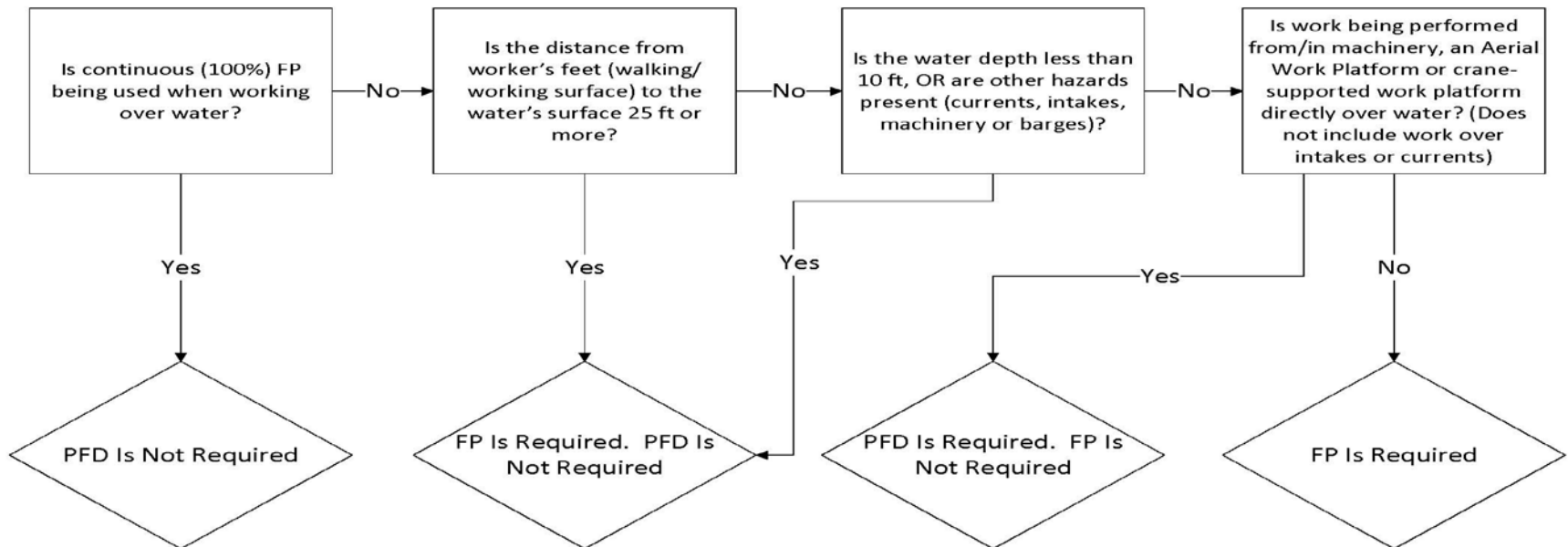

Section 22 - Work Platforms & Scaffolding

Section 22.A – General. Updated this section to contain standards that apply to both scaffolds & work platforms (not just scaffolds as in 2008).

Rationale: Better organized.

22.A.02 – Added specific language from OSHA regarding the use of cross bracing for guardrail/mid-rail.

Changed Subsection 22.B to address only scaffolds.

Rationale: As stated above.



Section 22 - Work Platforms & Scaffolding

22.B.01 – Requires AHA for scaffolding prior to erection, to include: An evaluation of site conditions, dimensions of scaffold, load calculations, wind loading, name of CP & barricading if applicable.

Rationale: Goal is to improve quality of AHA & document actions that should be occurring already.

22.B.02 – added specific training requirements for a Competent Person for Scaffolding.

Rationale: Establishes a minimum level of competency; it is quantifiable so it will be easier to evaluate competency.



Section 22 - Work Platforms & Scaffolding

22.B.03 – Color coded tags are optional.

Rationale: Consistent with ANSI A10

22.B.03– Added requirements for a Competent Person to inspect daily and to document on the already required daily safety inspection report.

Rationale: Tightens up the inspection process.



Section 22 - Work Platforms & Scaffolding

22.B.04 – added requirement to re-inspect scaffold if hoisted after assembly.

Rationale: Should be done anyway since the scaffold technically isn't complete until it is in place.

22.B.09.d – Requires a qualified person to determine wind loads when scaffolds are enclosed with plastic or other covering.

Rationale: Recommended by SAIA experts.



Section 22 - Work Platforms & Scaffolding

22.B.12 Scaffolds shall be plumb & level unless designed by PE to contour to structure.

Rationale: Recommended by SAIA experts to allow engineered configurations



Section 22 - Work Platforms & Scaffolding

22.A.15g – Added standard for distances between work platforms and buildings or work surfaces.

Rationale: Long standing OSHA requirement that should have been added years ago; eliminated reference to “outrigger scaffolds” as defined by ANSI A10.8 (see photo) which allows a 3 inch gap maximum. Outrigger scaffolds are rarely seen and this 3 inch requirement caused confusion.

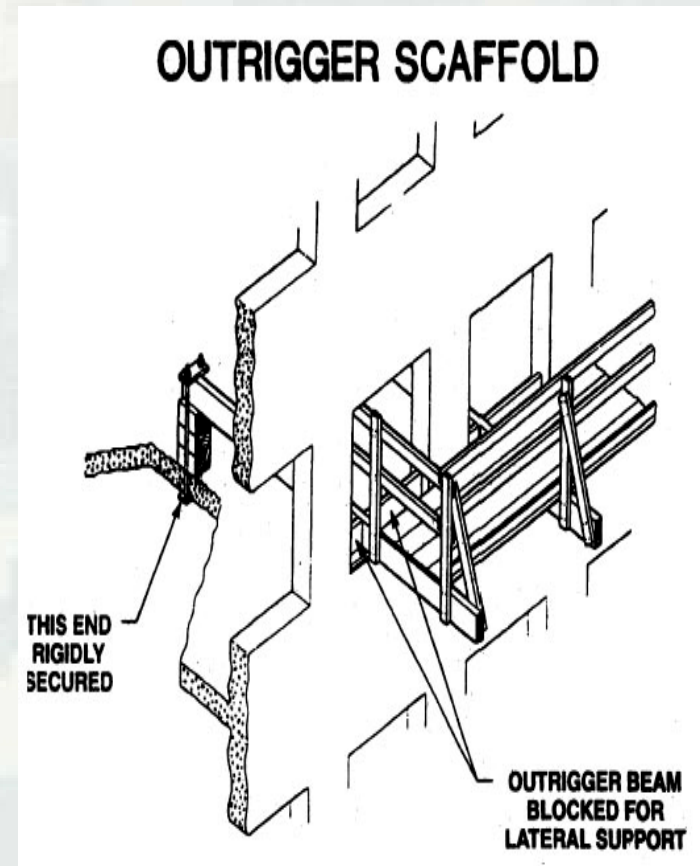

Section 22 - Work Platforms & Scaffolding

22.B.21 When vehicles or mobile equipment are used or allowed adjacent to scaffolding, substantial stop logs or barricades shall be installed.

a. The use of a ground guide is recommended, however, if it is demonstrated that barricades are not feasible or are not required based on distance, a ground guide shall be used.

b. Ground guides will not be exposed to potential falling objects from the scaffold or the equipment.

c. Hanging scaffolds are exempt unless the CP determines that vehicles or mobile equipment could pose a hazard to safe operation.

Rationale: Corrective action from an accident that could have easily been a fatality. Written to allow flexibility.



Section 22 - Work Platforms & Scaffolding

Suspended Work Platforms

22.E.02.c – Each hoist shall be inspected by a competent person before use, after every installation and re-rigging in accordance with the manufacturer's specifications. A trial operation will be done by the operator alone after every installation.

Rationale: Consistent with ANSI A10.8.



Section 22 - Work Platforms & Scaffolding

Suspended Work Platforms

22.E.03 Only personnel trained in the use of the suspended work platform shall be authorized to operate it. Anyone involved in erecting, disassembling, moving, operating, using, repairing, maintaining or inspecting a suspended scaffolds shall be trained by a Competent Person to recognize any hazards associated with the work in question. Proof of training shall be maintained on site and made available to the GDA upon request.

Rationale: Needed to establish verifiable training level; consistent with ANSI A10.8



Section 22 - Work Platforms & Scaffolding

Aerial Work Platforms

22.M.04 Transporting.

a. When manufacturers allow mobile operation the worksite shall be inspected for:

(1). Untamped earth fills (soft ground);

(2). Ditches;

(3). Drop offs and floor obstructions;

(4). Debris;

(5). Overhead obstructions and electrical conductors;

(6). Weather conditions; and,

(7). The presence of unauthorized persons.



Section 22 - Work Platforms & Scaffolding

Aerial Work Platforms

22.M.05 Operating practices. The manufacturer's instruction for control station operation must be followed, e.g., primary versus secondary; upper versus lower.

d. Lift controls will be located below the guardrail height. When lift controls are not located below the guardrail height an aftermarket guard will be installed.

f(4).... This practice shall be documented in the applicable AHA.

Rationale: Required by ANSI A92.6 and in response to serious accident.



Section 22 - Work Platforms & Scaffolding

Mast-Climbing Work Platforms

22.N.02 A pre-use inspection will be performed prior to erecting the work platform, according to requirements set out in IFPA/SAIA and the manual.

Rationale: Required by ANSI A92.9

22.N.02a. An overhead inspection will be done to ensure that the work platform will not come in contact with any obstructions while moving up or down the mast. Special attention will be given to high voltage conductors. Once the voltage of the line(s) is established the minimum safe approach distance in table 11-1 of EM 385-1-1 will be used.

Rationale: Added reference to table 11-1 for clearance distances.



Section 22 - Work Platforms & Scaffolding

22.N.03 Only designated, and trained users shall operate the mast climbing work platform. Training records shall be maintained for at least three (3) years and maintained on-site. All personnel on the platform shall be trained per 22.N.15a below.

Rationale: Required by ANSI A92.2.

22.N.11c Prior to use at elevations of 20 ft (6 m) or more an emergency egress plan will be developed to evacuate workers from a platform that gets stuck in an elevated position 20 ft or more above the ground. If that plan includes descending the mast, all employees working on the platform will be provided fall arrest equipment and will be trained in its use.

Rationale: OSHA recommendation



Section 22 - Work Platforms & Scaffolding

22.R Forklift/PIT mounted work platforms (New section)

Rationale: - These platforms were not addressed in previous versions of EM 385-1-1. All of the requirements were derived from existing OSHA standards (29 CFR 1910.178(a)(4)) or from ASME B56.6

22.R.01 Forklifts/PITs will not be used to support work platforms unless all there is no other practical method. If a rough terrain forklift must be used all of the conditions in this section must be met.

There are 22 additional requirements not addressed in this presentation.



Section 22 - Work Platforms & Scaffolding

22.S – Work Stands (NEW SECTION)

Very common equipment used primarily by sheet rockers. Not previously addressed in EM 385-1-1. These are technically not work platforms; they are designed IAW ANSI ladders standards. They are included in this section because in practicality they are used as a “work platform”. They are not required to have a minimum platform width of 18 inches. They are available in heights up to six (6) but the Corps allows them up to four (4) feet only.

22.S.01 Work stands shall be designed in accordance with either ANSI A14.2 (aluminum) or ANSI A14.5 (plastic/fiberglass).

22.S.02 Work stands shall not have a working height exceeding four feet (1.2m).

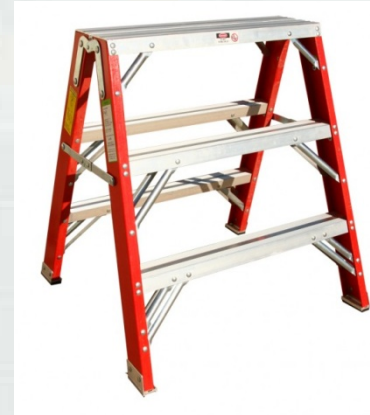

Section 22 - Work Platforms & Scaffolding

22.T – Trestle Ladders (NEW SECTION) All standards are per OSHA or ANSI.

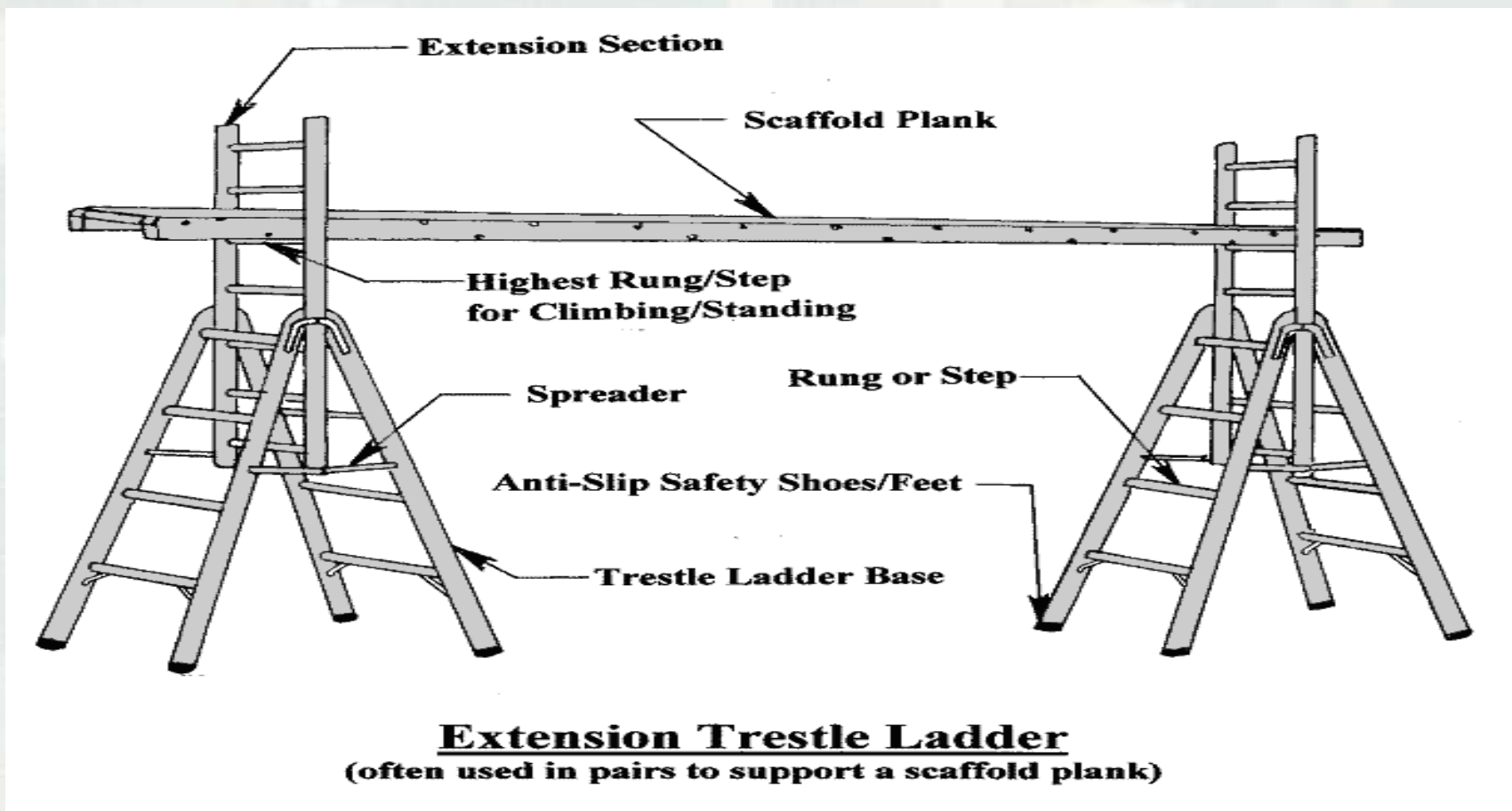

Section 22 - Work Platforms & Scaffolding

22.T – Trestle Ladders (NEW SECTION)

22.T.01 Scaffold platforms must be placed no higher than the second-highest rung or step of the ladder supporting the platform.

22.T.02 All ladders used in step, platform and trestle ladder scaffolds must:

a. Meet or exceed 29 CFR 1926 subpart X, except that job-made ladders are not permitted,

b. be prevented from slipping by how they are placed, fastened, or equipped.



Section 22 - Work Platforms & Scaffolding

Competent Person for scaffolding:

- must have received a documented, minimum of 8-hours of scaffold training to include **training on the specific type of scaffold** being used (e.g, Mast-climbing, adjustable, tubular frame, etc.), including assessment of the base material the scaffold will be erected upon, load calculations for materials and personnel, erection and dismantling.
- Documentation shall include training or experience on specific scaffolding systems/types.

Rationale: Needed to raise the bar on CP requirements because of the wide variety of scaffold systems available.



Section 23, Demolition, Renovation & Re-Occupancy

Section 23, Title Change from “Demolition” to “Demolition, Renovation, and Re-Occupancy”

- Need existed to segregate into these 3 main areas – clarifies many of the requirements and better defines what they are.
- Inserted Section 23.A “General” to define applicability.
- Adds and differentiates between renovation, structural demolition, soft demolition, mechanical demolition.

23.A.02 – Demolition and renovation activities require an Engineering Survey. A “note” has been added that the engineering survey is not required for soft demolition or renovation activities as long as no load bearing structure will be removed or demolished.





Section 23, Demolition, Renovation & Re-Occupancy

23.A.02.a(2) – Describes Demolition/Renovation Plan, when it's required and what is in it.

23.A.02.d – added wording that requires verification that disconnection or de-energizing has occurred.

23.A.05 and 14 – speaks to ACM and ORMs being removed IAW federal/state laws.

We felt it needed to be better clarified.

New: Para.23.B: Structural Demolition – almost all new. Discusses CP involvement; use of LHE; Structural, Soft and Mechanical Demolition requirements.



Section 24 – Safe Access

24.B.12. Use of Ladders

a. Ladders shall be restricted to their intended use. **Three points of contact** shall be maintained at all times when ascending or descending ladders. Three point contact means that either both hands and one foot, or both feet and one hand are in contact with the climbing device at all times.

Rationale: Refinement of ladder standards.



Section 25, Excavation and Trenching

25. A.01 Excavation/Trenching Plan and Activity Hazard Analysis (AHA). An Excavation/Trenching Plan and/or AHA will be prepared by the Competent Person or a Registered Professional Engineer, submitted and accepted by the GDA prior to beginning operations.
- a. For excavations or trenches greater than 5 ft (1.5 m) in depth both an AHA and an Excavation/Trenching plan are required.
 - b. For excavations/trenches less than 5 ft (1.5 m) in depth, or made entirely in stable rock, an AHA is required; an Excavation/Trenching plan is optional.

There are a lot of inquiries about excavations/trenches less than 5 ft (1.5m) in depth and what the safety requirements are. Correctly completing an AHA utilizing the competent person will not only identify the safety requirements and hazards but what will be done to mitigate them prior to digging.



Section 25, Excavation and Trenching

Para. 25.A.01.c: AHA shall include:

- (1) For all piping activities, shall include workers increased exposure during connection activities i.e. bent over or kneeling;
- (2) Include proposed methods and locations for egress;

Not only was the AHA added to the excavation plan but the team determined that both piping activities and egress are the most common areas overlooked when completing an AHA. Exposure increases greatly when workers are bent over or kneeling in an excavation or trench.



Section 25, Excavation and Trenching

25.A.01.d. Rescue plan and procedures: A rescue plan shall be prepared and maintained when workers are working at depths in excess of 5 ft (1.5 m).

In over 90% of cave-ins there is no rescue! It becomes body recovery due to the failure to have qualified and properly trained rescue teams and the proper material to perform a rescue in close proximity of the cave-in site.

Does this mean that we expect every contractor that's digging a hole over 5 ft deep to have a trained rescue team sitting right next to it? NO! But we do expect that all required sloping, benching, shoring or protective systems will not only be discussed when completing an AHA but applied to whatever type of excavation and/or trench is being dug so that a rescue is Never needed !



Section 25, Excavation and Trenching

25.B.02 Rescue Plan and Procedures. The employer is required to provide prompt rescue to all buried workers.

- a. A written rescue plan shall be prepared by the Competent Person or a Registered Professional Engineer, submitted and accepted by the GDA prior to beginning operations and maintained when workers are working at depths of over 5ft (1.5m).
- b. The plan shall contain provisions for self-rescue and assisted rescue of any worker who is buried during a cave-in including rescue equipment. If other methods of rescue are planned (i.e. by a jurisdictional public or Government emergency rescue agencies), it shall be indicated in the rescue plan including how to contact and summon the agency to the mishap site.



Section 25, Excavation and Trenching

25.A.02 Excavation inspection and testing.

c. When persons for the purpose of inspection/testing will be in or around an excavation that is deeper than 6ft (1.8m) but less than 20ft (6.1m) or contains hazards (e.g., impalement hazards, hazardous substances) shall be provided with fall protection IAW Section 21:

EXCEPTION: The Designated Competent Person may exempt the use of fall protection for inspectors/supervisors provided those individuals are not exposed to hazards within 24 inches of edges, the excavation contains no hazards and the individual(s) stay a minimum of 24 inches from the excavation edge.

This change was made per the comment forms and puts the burden of determining when fall protection is necessary for inspectors/supervisors on the Competent Person.



Section 25, Excavation and Trenching

25.C.01 Sloping or benching of the ground shall be in accordance with one of the systems outlined below as per OSHA 29 CFR 1926, *Subpart P, Appendix B*.

- d. Design by a RPE. The sloping or benching systems was not created using Options a, b or c above but is instead, approved by a RPE. At least one copy of the design shall be maintained at the job site during excavation. Designs shall be in writing and include:

Appendix B is the same information as Figure 25-1. What it doesn't say is a RPE can design a system and certify it. OSHA Std 1926.652(b)(4): Option (4) - Design by a registered professional engineer is the reference where OSHA allows the RPE to use their own design. Clarifies the requirement.



Section 27, Concrete, Masonry, Roofing and Residential Construction

Title Change – Added Roofing; Removed Steel Erection to its own Section 28

New 27.A.04 - Based on hazard evaluations conducted by supervisors, employers shall identify and select, and each affected employee shall use, personal protective equipment (PPE) and safety equipment that will provide appropriate protection for the work being performed. All PPE (i.e., for eyes, face, head and extremities, protective clothing, respiratory devices and protective shields and barriers) shall be provided, used, and maintained in a sanitary and reliable condition whenever the hazard dictates. > See 29 CFR 1910.132

Para 27.C.02.b, ADDED b. The design of the shoring shall be prepared by a qualified person (designer) and the erection and removal plans for formwork and shoring shall be submitted for review to the GDA. The erected shoring shall be inspected by an engineer qualified in structural design.



Section 27, Concrete, Masonry, Roofing and Residential Construction

Para 27.C. 09.h (4) Each post (near the slab perimeter) shall be secured during mantling and dismantling/re-shoring to prevent the post from “fall out”.

Para 27.C.12.a Vertical slip forms shall be planned and designed by an RPE.

Section 27.F Change to: 27.F Masonry Construction. > See also *Standard Practice for Bracing Masonry Walls Under Construction*, by the Council for Masonry Wall Bracing.

27 F.01 Prior to the beginning of the erection of any structural masonry, a Masonry Bracing Plan shall be submitted to the GDA for review and acceptance. The plan will include the identification of the site and project and will be signed and dated by the Qualified Person(QP) responsible for its preparation and modifications. The plan shall include the following information, as applicable to the particular project:



Section 27, Concrete, Masonry, Roofing and Residential Construction

27.F.02 A restricted zone shall be established whenever a masonry wall is being constructed. The restricted zone is created to keep masons and other tradesmen away from a wall under construction when winds exceed critical velocities until the wall is completely tied into the rest of the structure.

27.G Roofing. Added CP for FP: 27.G.01 Before work begins, a Competent Person for Fall Protection (CP for Fall Protection) shall complete a daily inspection of each job site. The CP for Fall Protection, designated by management, shall be capable of identifying existing predictable fall hazards and has the authority to take prompt corrective action to eliminate them. Hazards ...”



Section 28, Steel Erection

Section 28 Steel Erection – New section pulled out of Section 27;
Parallels 29 CFR 1926 standard.

Section 28 B.01.b: add (4) If lifting equipment other than crane or derrick (e.g. all-terrain forklifts or PITs) is used, it must be used in accordance with the manufacturers' instructions. If LHE is used with rigging, see also Section 16.

Rationale: Re-aligned new/old sections. LHE is misunderstood and this clarifies.



Section 28, Steel Erection

Section 28.B.02: deleted “curtain walls, window walls, and siding systems” to be more in line with steel erection activities

Section 28 B.03 – Deleted list of activities covered and added reference to “Refer to 29 CFR 1926.750 (b)(2) for a list of activities that are covered (but may not normally be considered) and occur during and are a part of steel erection activities.”

- Added Figures 28-1 and 28-2 for clarification on controlling double connection hazards.
- Clearer Figures for OSHA Bridging Terminus Points



Section 29, Blasting

Added applicability statement.

29.A General. This section applies to blasting activities performed by DA civilians or under DA contract with the use of commercial explosives on non-military lands/installations. For all other blasting activities, see Section 01.G.

Rationale: clarifies applicability and forwards reader to other activity references.



Section 29, Blasting

Added new Prerequisite:

29.A.01 Prerequisites.

- a. An Explosives Safety Site Plan (ESSP), approved by DoD Explosives Safety Board, IAW DA Pam 385-64 and DA Pam 385-65, is required prior to the placement of explosives on site or the start of explosives-related operations.

Rationale: ESSP required by DA Pam 385-64 and DA Pam 385-65. New DA requirements.



Section 30 – Diving Operations

30.A.02 Diving shall not be used as a work method if the work objective can be more safely and efficiently accomplished by another means, including but not limited to, using Remotely Operated Vehicles (ROV's), and/or camera systems, or by dewatering the work area so work may be accomplished in the dry.

Putting personnel in the water is a last resort – as far as feasibility or if the other methods create a hazardous situation.



Section 30 – Diving Operations

30.A.06 Proof of certification (a diploma and/or official transcript) as a commercial working diver from an accredited commercial dive school and other dive-related training certificates (e.g. chamber operator, saturation diver, etc.) are required as proof of a dive team member's certification and/or experience. An ADCI card or similar certification from an internationally recognized commercial diving organization may be substituted as proof of training for divers demonstrating more than five (5) years of diving experience within the six (6) years preceding beginning of dive operations.

Defines what certification documentation means – copies of all dive-related training/certification must be provided.



Section 30 – Diving Operations

Added wording in 30.A.14.c. To deal with diving in contaminated water.

Diving in contaminated water is prohibited for all USACE projects unless supporting documentation is provided that demonstrates that divers and topside personnel are not exposed to, or will be protected from, known or potential contamination hazards that would pose a chronic or acute health risk.

- (1) All divers and topside personnel shall be trained, equipped and resourced to dive in contaminated water.
- (2) The dive plan shall be accepted by the GDA within 10 business days prior to dive operations and shall specifically address the areas below in accordance with the *U.S. Navy Guidance For Diving In Contaminated Waters*, SS521-AJ-PRO-010 located at the U.S. Navy SEA 00C3 website:

...



Section 30 – Diving Operations

Para. 30.B.06.d. If divers are required to perform rigging duties, they must be a qualified rigger and meet the personnel qualifications listed in Section 15.B.

30.B.08 Underwater Welding and Burning Operations.

- a. Underwater welding and burning shall be limited to SSA mode only.
- b. Equipment configuration and procedures shall be in accordance with the *U.S. Navy Underwater Cutting & Welding Manual, S0300-BB-MAN-010.*



Section 30 – Diving Operations

- c. Divers performing underwater welding and burning operations shall be equipped with the following as a minimum:
- (1) A rubber or neoprene dive suit in good condition that provides electrical insulation to the diver;
 - (2) Insulating gloves with a cuff that, as a minimum, reaches and fully covers the wrist;
 - (3) A welding/burning eye shield attached to the dive helmet with appropriate shade for the conditions at the working area.



Section 31 - Tree Maintenance

Para 31.A.02: Tree maintenance or removal shall be performed under the direction of a qualified tree worker and in accordance with references above. The services of a certified arborist may also be necessary to properly access the required maintenance to be performed.

Amended to read; The services of other licensed or credentialed professionals may be necessary to properly address the required maintenance to be performed and/or hazards that may be encountered. Examples of credentialed professionals include but are not limited to: TCIA-accredited Tree Care Company, Certified Arborist, Licensed Tree Expert, Certified Treecare Safety Professional (CTSP), Certified Crane Operator/Rigger/Signalperson, or Certified Utility Safety Professional (CUSP).

Rationale: Needed to define qualified tree worker.



Section 31, Tree Maintenance

Para. 31.B.07 now 31.B.08: changed wording to;

31.B.08 The climber working from a stem or spar without a suitable natural crotch shall select tie-in points or a tie-in method that positively prevent the climbing line from sliding down or up, or off the stem during climbing operations. Placing a climbing line around a stem in an area without a lateral limb is not acceptable unless the climbing line is cinched or choked around the stem or runs through a double-wrapped or adjustable false crotch, which is secured/cinched around the stem. The tie-in point selected shall be able to withstand the forces being applied during the pruning/removal operation.

OLD Section 31.B.07

The tree worker shall be completely secured with the climbing line before starting the operation. The climbing line shall be crotched as soon as practicable after the employee is aloft, and a taut-line hitch tied and checked. The worker shall remain tied in until the work is completed and he/she has returned to the ground. If it is necessary to recrotch the rope in the tree, the worker shall retie in or use the safety strap before releasing the previous tie.

Rationale: Amended paragraph based on 2012 version of Z133. Changes were based on the hazards that caused a lot of deaths and serious injuries recently.



BUILDING STRONG®

Section 31 - Tree Maintenance

Para. 31.C.10: Removed last line of paragraph that stated, “Manufacturer’s recommendations will be strictly followed when using a loader, skid steer, or similar piece of equipment to push directly against the tree.”

Rationale: No manufacturer would condone pushing trees with any of the equipment listed, much less write instructions for it. Several people are killed every year when attempting to push trees with excavators, bulldozers, bobcats, etc. It is simply not a safe practice.



Section 31, Tree Maintenance

Para 31.C.01: Added to list of potential hazards to be considered while doing this type of work to include UXO (Unidentified Explosive Ordinance) as follows;

Prior to felling operations, the employee shall consider the associated hazards that may include, but are not limited to: a. Tree size (Will it fit in the landing zone?) Measure tree height; b. Selected direction of fall; c. Felling path obstacles to avoid or clear; d. Vines or interlocking limbs; e. Species and shape of tree; f. Lean of tree; g. Loose limbs, hangers, broken tops, chunks, or other overhead material; h. Wind force and direction; i. Decay, cavities, or weak spots throughout the tree; j. Location of any electrical conductors or other wires; k. Tree cables, bracing, lightning protection, or other tree hardware; l. Size and terrain characteristics or limitations of work area; m. Potential for flying debris from tree impact; n. Adequate retreat path; o. Evidence of bees or wildlife habitation in tree; p. Poisonous plants, water hazards; q. Ability to control access to work site; r. Authority to remove tree; s. Quality of wood fiber in hinge area; t. Root mass stability; u. Ice or snow load; v. Throw-back or bounce-back potential; w. Potential for spring poles; x. Lodged trees or dead snags in area; y. Access to tools or resources required for task; z. Lightning damage; aa. Barber chair potential; bb. Foreign objects, nails, wire fence, concrete, etc. in the tree. cc. Unidentified Explosive Ordinance (UXO)



Section 31, Tree Maintenance

Para 31.C.06: Reworded and amended to read, 31.C.06 A notch and backcut shall be used in felling trees over 5 in (12.7 cm) in diameter (measured at breast height) No tree shall be felled by “slicing” or “ripping” cuts.

a. The two cuts that form the notch shall meet at a point called the apex, and shall not cross that point or go beyond the point where they meet.

b. The notch cut used shall be a conventional notch, an open-face notch, or a Humboldt notch.

c. Notches shall be 45 degrees or greater and large enough to guide the fall of the tree or trunk.

d. Notch depth should not exceed one-third the diameter of the tree. The hinge width should be 80 percent of the tree’s diameter, as measured at the hinge.



Section 31, Tree Maintenance

e. Saw cuts made to form the notch and back cut shall leave suitable amounts of hinge wood to adequately control the directional fall of the tree.

f. With a conventional notch or Humboldt notch, the back cut shall be 1 to 2 inches (2.5 to 5cm) above the apex of the notch to provide an adequate platform to prevent kickback of the tree or trunk. With an open-face notch (greater than 70 degrees), the back cut should be at the same level as the apex of the notch.

Rationale: Additional detail added to this hazardous activity for clarity for both those performing this work and for those overseeing this work.



Section 32 – Airfield and Aircraft Operations

New Requirements:

32.A.02 Construction Safety and Phasing Plan (CSPP) and a Safety Plan Compliance Document (SPCD). Prior to the performance of any work upon or around an airfield, a CSPP and a SPCD will be prepared by a Competent Person (CP). The CSPP will follow the guidelines found in the most current edition of Federal Aviation Administration (FAA) Advisory Circular AC No: 150/5370-2F, Operational Safety on Airports During Construction.



Section 32 – Airfield and Aircraft Operations

New Requirements:

32.A.06 Excavations.

- a. Open trenches or excavations are not permitted within the Runway Safety Area while the runway is open or on the Taxiway Surface Area while the taxiway is open. If possible, backfill trenches before the runway or taxiway is opened. If the runway or taxiway must be opened before excavations are backfilled, cover the excavations appropriately. Covering for open trenches must be designed to allow the safe operation of the heaviest aircraft operating on the runway across the trench without damage to the aircraft.



Section 32 – Airfield and Aircraft Operations

New Requirements:

32.A.14 Prohibitions.

- a. No use of tall equipment (cranes, concrete pumps, etc.) unless an FAA Form 7460-1 determination letter is issued for such equipment.
- b. No use of open flame welding or torches unless fire safety precautions are provided and the airport operator has approved their use.



BUILDING STRONG®

Section 32 – Airfield and Aircraft Operations

New Requirements:

32.A.14 Prohibitions.

- c. No use of electrical blasting caps on or within 1,000 ft (300 m) of the airport property.
- d. No use of flare pots within the AOA.



Section 33, HAZWOPER (Formally Section 28)

Section number changed from Section 28 to Section 33

33.B.01 Hazardous waste site cleanup operations require development and implementation of a SSHP that shall be attached to the Accident Prevention Plan (APP) as an appendix. Information from the APP should not be duplicated in the SSHP.

Addition to clarify for both contract and USACE personnel the relationship between the SSHP and the AAP



Section 33, HAZWOPER (Formally Section 28)

33.B.01 Added the following two paragraphs

e. A SSHP is not required for contracts where the site has been fully characterized and there is no known OR anticipated potential for employee contamination-related exposures during the tasks being performed.

f. If the work meets the criteria in Section 33.B.01.e and the tasks being performed are limited in scope (e.g., mowing, routine maintenance, or utility checks of existing equipment as part of long-term maintenance or site management), an abbreviate APP as described in Section 01.A.12.e may be used in lieu of a full APP.

Addition was to allow non-hazardous work to be completed as it would on a non-hazardous work site.



Section 33, HAZWOPER (Formally Section 28)

33.C.01 Added: The Safety and Health Manager (SHM) must meet the qualifications and fulfill the responsibilities stated below for all hazardous waste operations.

Clarify the responsibilities and qualifications of the SHM on HAZWOPER Sites.

33.C.02 Added: a. The SSHO shall have a minimum 1 year experience implementing safety and occupational health procedures at cleanup operations and shall meet 29 CFR 1910.120/29 CFR 1926.65 requirements for 40 hour initial and 8 hour supervisor training and, maintain 8 hour refresher training requirements. In addition, for supervision of safety and health at projects involving intrusive activities, the SSHO shall meet the qualifications for SSHO specified in section 01.A.17 b. Intrusive activities include, but are not exclusive to, drilling, demolition, and excavation.

Added to clarify the training required for tasks with lower hazards on HAZWOPER Sites.



Section 34 - Confined Space Entry

34.A.02

- b. On construction sites and/or during O&M activities, all fixed PRCS shall be labeled as a Danger. PRCS that are created as part of construction work shall be labeled and have a barrier to restrict entry. All Non Permit-Required Confined Spaces (NPRCS) created as part of construction and/or O&M activities are not required to be labeled.



Section 34, Confined Space Entry

Added a Flow Chart to aid in determination of a permit required and non-permit required confined space added a sample confined space permit.

Clearly defines the responsibility of the entry supervisor or manager and the Confined Space Competent Person to identify who is responsible and to be in compliance with 1910.146.

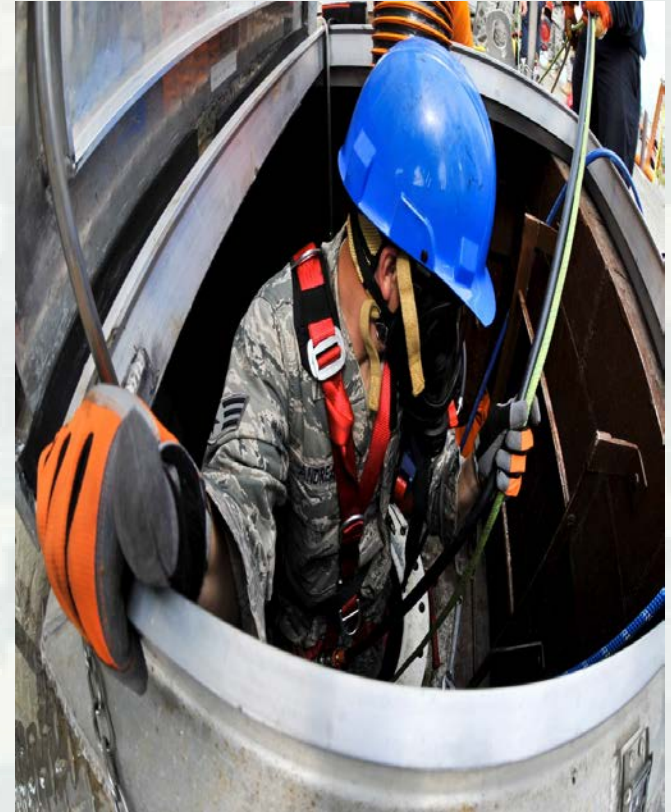

Section 34, Confined Space Entry



34.A.07.c.(1) NPRCS Added: .
Describe the potential atmospheric and/or physical hazards that are present in the CS and the necessary controls for these hazards, necessary training requirements of entrants and workers within visual contact.



Section 34, Confined Space Entry

34.A.07. Added language: On notifying emergency services of pending entry and the nature of the hazards in the confined space.

34.A.08 Employee Training. Required not only the confined space entrants and the attendant to be trained, but an awareness training for adjacent workers. Clearly defined what is to be in the training. Required a review of the training before each entry.



Section 34, Confined Space Entry

34.B.01 Added definitions of confined spaces on vessels to clarify intent

a. If the potential CS has an oxygen deficient atmosphere, the space shall be labeled “Not Safe for Workers”.

b. If the potential CS has a oxygen-enriched atmosphere, the space shall be labeled “Not Safe for Workers – Not Safe for Hot Work.”

c. If the potential CS contains a flammable gases or vapors at 10% or higher than the lower explosive limits for the gases, then the space shall be labeled “Not Safety for Workers – Not Safe for Hot Work.”

d. If the CS contains a potential atmosphere that is toxic, corrosive, or irritants that exceed the OEL, the space shall be labeled “Not Safe for Workers”.



Section 34, Confined Space Entry - Vessels

34.B.02 – Added: Before and during entry... At a minimum the entry log or form shall have the time and date, monitoring device type, model, serial number, and calibration date, and the name of the individual doing the testing.

- Based on total lack of documentation on monitoring on vessels.
- Required the air monitoring to be before each entry.
- Increased the training requirements.
- Restricted hot work and required more training and air monitoring for hot work in confined spaces on vessels.



EM 385-1-1 2015 Implementation

Questions?

